



## **Installation and Operation Manual**

# **RXTS Series**

U-Rack Window Type  
Room Air Conditioner

RXTS-81A  
RXTS-101A  
RXTS-121A



## Table of Contents

<b>Important Safety Instructions .....</b>	<b>03</b>
<b>Installation Instructions.....</b>	<b>14</b>
<b>Normal Sounds / Sound Performance.....</b>	<b>28</b>
<b>Air Conditioner Features.....</b>	<b>29</b>
<b>Care and Cleaning.....</b>	<b>33</b>
<b>Troubleshooting Tips.....</b>	<b>34</b>

# Important Safety Instructions

## READ THIS MANUAL

Inside you will find many helpful hints on how to use and maintain your air conditioner properly. Just a little preventive care on your part can save you a great deal of time and money over the life of your air conditioner. You'll find many answers to common problems in the chart of troubleshooting tips. If you review our chart of Troubleshooting Tips first, you may not need to call for service at all.

To prevent injury to the user or other people and property damage, the following instructions must be followed. Incorrect operation due to ignoring of instructions may cause harm or damage. The seriousness is classified by the following indications.

	<b>DANGER</b>	This symbol indicates the probability of death or serious injury.
	<b>WARNING</b>	This symbol indicates the possibility of death or serious injury .
	<b>CAUTION</b>	This symbol indicates the possibility of injury or damage to property.
	<b>NOTICE</b>	Indicates information considered important, but not hazard-related.
	<b>Never do this.</b>	
		<b>Always do this.</b>

<b>DANGER</b>		
<p> Plug in power plug properly.</p>	<p> Do not operate or stop the unit by inserting or pulling out the power plug.</p>	<p> Do not damage or use an unspecified power cord.</p>
<ul style="list-style-type: none"> <li>• Otherwise, it may cause electric shock or fire due to excess heat generation.</li> </ul>	<ul style="list-style-type: none"> <li>• It may cause electric shock or fire due to heat generation.</li> </ul>	<ul style="list-style-type: none"> <li>• It may cause electric shock or fire.</li> <li>• If the power cord is damaged, it must be replaced by the manufacturer or an authorised service centre or a similarly qualified person in order to avoid a hazard.</li> </ul>
<p> Always ensure effective grounding.</p>	<p> Do not operate with wet hands or in damp environment.</p>	<p> Do not allow water to run into electric parts.</p>
<ul style="list-style-type: none"> <li>• Incorrect grounding may cause electric shock.</li> </ul>	<ul style="list-style-type: none"> <li>• It may cause electric shock .</li> </ul>	<ul style="list-style-type: none"> <li>• It may cause failure of machine of electric shock.</li> </ul>
<p> Do not modify power cord length .</p>	<p> Do not use the socket if it is loose or damaged.</p>	<p> Unplug the unit if strange sounds, smell, or smoke comes from it.</p>
<ul style="list-style-type: none"> <li>• It may cause electric shock or fire due to heat generation.</li> </ul>	<ul style="list-style-type: none"> <li>• It may cause fire and electric shock.</li> </ul>	<ul style="list-style-type: none"> <li>• It may cause fire and electric shock.</li> </ul>

**⚠ DANGER**

- |  |  |
|--|--|
| <ul style="list-style-type: none"> <li>⊘ Do not disassemble or modify unit.</li> <li>• It may cause failure and electric shock.</li> </ul> | <ul style="list-style-type: none"> <li>⊘ Do not open the unit during operation.</li> <li>• It may cause electric shock.</li> </ul> |
|--|--|

**⚠ WARNING**

- |   |   |  |
|---|---|--|
| <ul style="list-style-type: none"> <li>⊘ Always install circuit breaker and a dedicated power circuit.</li> <li>• Incorrect installation may cause fire and electric shock.</li> </ul>                    | <ul style="list-style-type: none"> <li>⊘ Do not direct airflow at room occupants only.</li> <li>• This could damage your health.</li> </ul>                 | <ul style="list-style-type: none"> <li>⊘ Do not use the power cord near flammable gas or combustibles, such as gasoline, benzene, thinner, etc.</li> <li>• It may cause an explosion or fire.</li> </ul> |
| <ul style="list-style-type: none"> <li>⊘ Keep firearms away.</li> <li>• It may cause fire.</li> </ul>   | <ul style="list-style-type: none"> <li>⊘ Do not use the power cord close to heating appliances.</li> <li>• It may cause fire and electric shock.</li> </ul> |  |
| <ul style="list-style-type: none"> <li>⊘ Ventilate room before operating air conditioner if there is a gas leakage from another appliance.</li> <li>• It may cause explosion, fire and, burns.</li> </ul> |   |  |

**⚠ CAUTION**

- |   |  |   |
|---|--|---|
| <ul style="list-style-type: none"> <li>⊘ When the air filter is to be removed, do not touch the metal parts of the unit.</li> <li>• It may cause an injury.</li> </ul>  | <ul style="list-style-type: none"> <li>⊘ Do not put a pet or house plant where it will be exposed to direct air flow.</li> <li>• This could injure the pet or plant.</li> </ul>                  | <ul style="list-style-type: none"> <li>⊘ Ventilate the room well when used together with a stove, etc.</li> <li>• An oxygen shortage may occur.</li> </ul>  |
| <ul style="list-style-type: none"> <li>⊘ Do not use strong detergent such as wax or thinner but use a soft cloth.</li> <li>• Appearance may be deteriorated due to change of product color or scratching of its surface.</li> </ul> | <ul style="list-style-type: none"> <li>⊘ Do not clean the air conditioner with water.</li> <li>• Water may enter the unit and degrade the insulation. It may cause an electric shock.</li> </ul> | <ul style="list-style-type: none"> <li>⊘ Do not use for special purposes.</li> <li>• Do not use this air conditioner to preserve precision devices, food, pets, plants, and art objects. It may cause deterioration of quality, etc.</li> </ul> |



**⚠ CAUTION**

- |   |   |   |
|---|---|---|
| Ⓞ Stop operation and close the window in storm or hurricane.                                    | Ⓞ When the unit is to be cleaned, switch off, and turn off the circuit breaker.                       | Ⓞ Ensure that the installation bracket of the outdoor appliance is not damaged due to prolonged exposure.   |
| • Operation with windows opened may cause wetting of indoor and soaking of household furniture. | • Do not clean unit when power is on as it may cause fire and electric shock, it may cause an injury. | • If bracket is damaged, there is concern of damage due to falling of unit.   |
| Ⓞ Always insert the filters securely. Clean filter once every two weeks.                        | Ⓞ Hold the plug by the head of the power plug when taking it out.                                     | Ⓞ Turn off the main power switch when not using the unit for a long time.   |
| • Operation without filters may cause failure.  | • It may cause electric shock and damage.   | • It may cause failure of product or fire.  |
| Ⓞ Do not place obstacles around air-inlets or inside of air-outlet.                             | Ⓞ Do not place heavy object on the power cord and ensure that the cord is not compressed.             | Ⓞ Do not drink water drained from air conditioner.  |
| • It may cause failure of appliance or accident.  | • There is danger of fire or electric shock.  | • It contains contaminants and could make you sick.   |
| Ⓞ Use caution when unpacking and installing. Sharp edges could cause injury.                    |   | Ⓞ If water enters the unit, turn the unit off at the power outlet and switch off the circuit breaker. Isolate supply by taking the power-plug out and contact a qualified service technician. |

**⚠ CAUTION**

- This appliance is not intended for use by people (including children) with reduced physical, sensory, or mental capabilities or lack of experience and knowledge, unless they have been given supervision or instruction concerning use of the appliance by a person responsible for their safety.
- Children should be supervised to ensure that they do not play with the appliance.
- If the power cord is damaged, it must be replaced by the manufacturer, its service agent, or similarly qualified person in order to avoid a hazard.
- The appliance shall be installed in accordance with national wiring regulations.
- Do not operate your air conditioner in a wet room such as a bathroom or laundry room.
- The appliance with electric heater shall have at least 1 meter of space to the nearest combustible material.
- Contact the authorized service technician for repair or maintenance of this unit.

**NOTICE:**

The power supply cord with this air conditioner contains a current detection device designed to reduce the risk of fire. Please refer to the section Operation of Current Device for details. In the event that the power cord is damaged, it cannot be repaired – it must be replaced with a cord from the product manufacturer.

**WARNING**

Avoid fire hazard or electric shock. Do not use an extension cord or an adapter plug. Do not remove any prongs from the power cord.

Grounding type wall receptacle

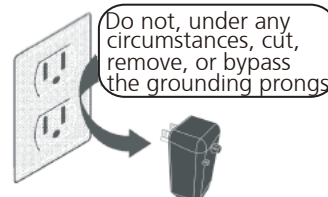

Power supply cord with 3-prong grounding plug and current detection device.

**DANGER**

**For Your Safety**

Do not store or use gasoline or other flammable vapors and liquids in the vicinity of this or any other appliance.

**DANGER**

**Prevent Accidents**

To reduce the risk of fire, electrical shock, or injury when using your air conditioner, follow basic precautions, including the following:

- Be sure the electrical service is adequate for the model you have chosen. This information can be found on the serial plate, which is located on the side of the the cabinet and behind the grille.
- It is recommended to clean both sides of the window glass first. If the window has a screen panel included on the lower portion, the screen panel should be removed before installation.
- Be sure the air conditioner has been securely and correctly installed according to the installation instructions in this manual. Save this manual for possible future use in removing or installing this unit.
- When handling the air conditioner, be careful to avoid cuts from the sharp metal fins on the front and rear coils.

**WARNING**

**Electrical Information**

The complete electrical rating of your new room air conditioner is stated on the serial plate. Refer to the rating when checking the electrical requirements.

- Be sure the air conditioner is properly grounded. To minimize shock and fire hazards, proper grounding is important. The power cord is equipped with a three-prong grounding plug for protection against shock hazards.
- Your air conditioner must be used in a properly grounded wall receptacle. If the wall receptacle you intend to use is not adequately grounded or protected by a time delay fuse or circuit breaker, have a qualified electrician install the proper receptacle. Ensure the receptacle is accessible after the unit installation.
- Do not run air conditioner without side protective cover in place. This could result in mechanical damage within the air conditioner.
- **Do not use an extension cord or an adapter plug.**

## Operation of Current Device (Applicable to only units with a current detection device)

The power supply cord contains a current device that senses damage to the power cord. To test your power supply cord do the following:

1. Plug in the Air Conditioner.
2. The power supply cord will have TWO buttons on the plug head. Press the TEST button, you will notice a click as the RESET button pops out.
3. Press the RESET button, again you will notice a click as the button engages.
4. The power supply cord is now supplying electricity to the unit. On some products, this is also indicated by a light on the plug head.

### NOTICE:

- Do not use this device to turn the unit on or off.
- Always make sure the RESET button is pushed in for correct operation.
- The power supply cord must be replaced if it fails to reset when either the TEST button is pushed or if it cannot be reset. A new one can be obtained from the product manufacturer.
- If power supply cord is damaged, it cannot be repaired. It MUST be replaced by one obtained from the product manufacturer.

**NOTE: This air conditioner is designed to be operated under the following conditions:**

Cooling operation	Outdoor temp:	64-109°F/18-43°C (64-125°F/18-52°C for special tropical models)
	Indoor temp:	60-90°F/16-32°C

**Note: Performance may be reduced outside of these operating temperatures.**

### **WARNING: (for using R290/R32 refrigerant only)**

- Do not try to accelerate the defrosting process or methods of cleaning that are not recommended by the manufacturer.
- The appliance shall be stored in a room without a continuously operating ignition source (for example, open flames or an operating gas appliance) or an ignition source (for example, an operating electric heater) close to the appliance. The appliance shall also be stored in a room without ignition sources.
- Do not pierce or burn.
- Be aware that the refrigerants may not contain an odor.
- Compliance with national gas regulations shall be observed.
- Keep ventilation openings clear of obstruction.
- The appliance shall be stored in a well-ventilated area where the room size corresponds to the room area as specified for operation.
- A warning that the appliance shall be stored in a well-ventilated area where the room size corresponds to the room area as specified for operation.
- Any person who is involved with working on or breaking into a refrigerant circuit should hold a current valid certificate from an industry-accredited assessment authority, which authorizes their competence to handle refrigerants safely in accordance with an industry recognized assessment specification.

**Important Safety Instructions**

- Servicing shall only be performed as recommended by the equipment manufacturer. Maintenance and repair requiring the assistance of other skilled personnel shall be carried out under the supervision of the person competent in the use of flammable refrigerants.
- DO NOT modify the length of the power cord or use an extension cord to power the unit. DO NOT share a single outlet with other electrical appliances. Improper power supply can cause fire or electrical shock.
- Please follow the instruction carefully to handle, install, clean, service the air conditioner to avoid any damage or hazard. Flammable Refrigerant R32 is used within air conditioner. When maintaining or disposing of the air conditioner, the refrigerant (R32 or R290) shall be recovered properly, ensuring not to discharge it to the air directly.
- No open fire or devices that generate spark/arcing shall be around the air conditioner to avoid causing ignition of the flammable refrigerant used. Please follow the instructions carefully to store or maintain the air conditioner to prevent mechanical damage from occurring.
- Flammable refrigerant (R32) is used in this air conditioner. Please follow the instructions carefully to avoid any hazards.





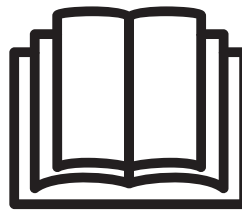

Caution: Risk of fire/  
flammable materials  
(Required for R32/R290 units only)



**IMPORTANT NOTE:** Read this manual carefully before installing or operating your new air conditioning unit. Make sure to save this manual for future reference.

**Explanation of symbols displayed on the unit (since the unit uses R32/R290 refrigerant):**

	<b>WARNING</b>	This symbol shows that this appliance used a flammable refrigerant. If the refrigerant is leaked and exposed to an external ignition source, there is a risk of fire.
	<b>CAUTION</b>	This symbol shows that the operation manual should be read carefully.
	<b>CAUTION</b>	This symbol shows that a service personnel should be handling this equipment with reference to the installation manual.
	<b>CAUTION</b>	This symbol shows that information is available such as the operating manual or installation manual.

## **WARNINGS (for using R290/R32 refrigerant only)**

- 1. Transport of equipment containing flammable refrigerants**  
See transport regulations
- 2. Marking of equipment using signs**  
See local regulations
- 3. Disposal of equipment using flammable refrigerants**  
See national regulations.
- 4. Storage of equipment/appliances**  
The storage of equipment should be in accordance with the manufacturer's instructions.
- 5. Storage of packed (unsold) equipment**  
Storage package protection should be constructed such that mechanical damage to the equipment inside the package will not cause a leak of the refrigerant charge.  
The maximum number of pieces of equipment permitted to be stored together will be determined by local regulations.
- 6. Information on servicing**
  - 1) Checks to the area  
Prior to beginning work on systems containing flammable refrigerants, safety checks are necessary to ensure that the risk of ignition is minimised. For repair to the refrigerating system, the following precautions shall be complied with prior to conducting work on the system.
  - 2) Work procedure  
Work shall be undertaken under a controlled procedure so as to minimise the risk of a flammable gas or vapour being present while the work is being performed.
  - 3) General work area  
All maintenance staff and others working in the local area shall be instructed on the nature of work being carried out. Work in confined spaces shall be avoided. The area around the workspace shall be sectioned off. Ensure that the conditions within the area have been made safe by control of flammable material.
  - 4) Checking for presence of refrigerant  
The area shall be checked with an appropriate refrigerant detector prior to and during work, to ensure the technician is aware of potentially flammable atmospheres. Ensure that the leak detection equipment being used is suitable for use with flammable refrigerants, i.e. non-sparking, adequately sealed or intrinsically safe.
  - 5) Presence of fire extinguisher  
If any hot work is to be conducted on the refrigeration equipment or any associated parts, appropriate fire extinguishing equipment shall be available to hand. Have a dry powder or CO2 fire extinguisher adjacent to the charging area.
  - 6) No ignition sources  
No person carrying out work in relation to a refrigeration system which involves exposing any pipe work that contains or has contained flammable refrigerant shall use any sources of ignition in such a manner that it may lead to the risk of fire or explosion. All possible ignition sources, including cigarette smoking, should be kept sufficiently far away from the site of installation, repairing, removing and disposal, during which flammable refrigerant can possibly be released to the surrounding space. Prior to work taking place, the area around the equipment is to be surveyed to make sure that there are no flammable hazards or ignition risks. No Smoking signs shall be displayed.

## ⚠️ WARNINGS (for using R290/R32 refrigerant only)

### 7) Ventilated area

Ensure that the area is in the open or that it is adequately ventilated before breaking into the system or conducting any hot work. A degree of ventilation shall continue during the period that the work is carried out. The ventilation should safely disperse any released refrigerant and preferably expel it externally into the atmosphere.

### 8) Checks to the refrigeration equipment

Where electrical components are being changed, they shall be fit for the purpose and to the correct specification. At all times the manufacturer's maintenance and service guidelines shall be followed. If in doubt consult the manufacturer's technical department for assistance.

The following checks shall be applied to installations using flammable refrigerants:

The charge size is in accordance with the room size within which the refrigerant containing parts are installed;

The ventilation machinery and outlets are operating adequately and are not obstructed;

If an indirect refrigerating circuit is being used, the secondary circuit shall be checked for the presence of refrigerant;

Marking to the equipment continues to be visible and legible. Markings and signs that are illegible shall be corrected;

Refrigeration pipe or components are installed in a position where they are unlikely to be exposed to any substance which may corrode refrigerant containing components, unless the components are constructed of materials which are inherently resistant to being corroded or are suitably protected against being so corroded.

### 9) Checks to electrical devices

Repair and maintenance to electrical components shall include initial safety checks and component inspection procedures. If a fault exists that could compromise safety, then no electrical supply shall be connected to the circuit until it is satisfactorily dealt with. If the fault cannot be corrected immediately but it is necessary to continue operation, an adequate temporary solution shall be used. This shall be reported to the owner of the equipment so all parties are advised.

Initial safety checks shall include:

That capacitors are discharged: this shall be done in a safe manner to avoid possibility of sparking;

That there no live electrical components and wiring are exposed while charging, recovering or purging the system;

That there is continuity of earth bonding.

## 7. Repairs to sealed components

1) During repairs to sealed components, all electrical supplies shall be disconnected from the equipment being worked upon prior to any removal of sealed covers, etc. If it is absolutely necessary to have an electrical supply to equipment during servicing, then a permanently operating form of leak detection shall be located at the most critical point to warn of a potentially hazardous situation.

2) Particular attention shall be paid to the following to ensure that by working on electrical components, the casing is not altered in such a way that the level of protection is affected. This shall include damage to cables, excessive number of connections, terminals not made to original specification, damage to seals, incorrect fitting of glands, etc. Ensure that apparatus is mounted securely.

## WARNINGS (for using R290/R32 refrigerant only)

Ensure that seals or sealing materials have not degraded such that they no longer serve the purpose of preventing the ingress of flammable atmospheres. Replacement parts shall be in accordance with the manufacturer's specifications.

NOTE: The use of silicon sealant may inhibit the effectiveness of some types of leak detection equipment. Intrinsically safe components do not have to be isolated prior to working on them.

### **8. Repair to intrinsically safe components**

Do not apply any permanent inductive or capacitance loads to the circuit without ensuring that this will not exceed the permissible voltage and current permitted for the equipment in use. Intrinsically safe components are the only types that can be worked on while live in the presence of a flammable atmosphere. The test apparatus shall be at the correct rating. Replace components only with parts specified by the manufacturer. Other parts may result in the ignition of refrigerant in the atmosphere from a leak.

### **9. Cabling**

Check that cabling will not be subject to wear, corrosion, excessive pressure, vibration, sharp edges or any other adverse environmental effects. The check shall also take into account the effects of aging or continual vibration from sources such as compressors or fans.

### **10. Detection of flammable refrigerants**

Under no circumstances shall potential sources of ignition be used in the searching for or detection of refrigerant leaks. A halide torch (or any other detector using a naked flame) shall not be used.

### **11. Leak detection methods**

The following leak detection methods are deemed acceptable for systems containing flammable refrigerants. Electronic leak detectors shall be used to detect flammable refrigerants, but the sensitivity may not be adequate, or may need re-calibration. (Detection equipment shall be calibrated in a refrigerant-free area.) Ensure that the detector is not a potential source of ignition and is suitable for the refrigerant used. Leak detection equipment shall be set at a percentage of the LFL of the refrigerant and shall be calibrated to the refrigerant employed and the appropriate percentage of gas (25 % maximum) is confirmed. Leak detection fluids are suitable for use with most refrigerants but the use of detergents containing chlorine shall be avoided as the chlorine may react with the refrigerant and corrode the copper pipe-work. If a leak is suspected, all naked flames shall be removed/ extinguished. If a leakage of refrigerant is found which requires brazing, all of the refrigerant shall be recovered from the system, or isolated (by means of shut off valves) in a part of the system remote from the leak. Oxygen free nitrogen (OFN) shall then be purged through the system both before and during the brazing process.

### **12. Removal and evacuation**

When breaking into the refrigerant circuit to make repairs or for any other purpose conventional procedures shall be used. However, it is important that best practice is followed since flammability is a consideration. Opening of the refrigeration systems shall not be done by brazing. The following procedure shall be adhered to:

Remove refrigerant;

Purge the circuit with inert gas;

Evacuate;

Purge again with inert gas;



## **⚠ WARNINGS (for using R290/R32 refrigerant only)**

Open the circuit by cutting or brazing.

The refrigerant charge shall be recovered into the correct recovery cylinders. The system shall be flushed with OFN to render the unit safe. This process may need to be repeated several times. Compressed air or oxygen shall not be used for this task.

Flushing shall be achieved by breaking the vacuum in the system with OFN and continuing to fill until the working pressure is achieved, then venting to atmosphere, and finally pulling down to a vacuum. This process shall be repeated until no refrigerant is within the system. When the final OFN charge is used, the system shall be vented down to atmospheric pressure to enable work to take place. This operation is absolutely vital if brazing operations on the pipe-work are to take place.

Ensure that the outlet for the vacuum pump is not close to any ignition sources and there is ventilation available.

### **13. Charging procedures**

In addition to conventional charging procedures, the following requirements shall be followed. Ensure that contamination of different refrigerants does not occur when using charging equipment. Hoses or lines shall be as short as possible to minimise the amount of refrigerant contained in them.

Cylinders shall be kept upright.

Ensure that the refrigeration system is earthed prior to charging the system with refrigerant. Label the system when charging is complete (if not already).

Extreme care shall be taken not to overfill the refrigeration system.

Prior to recharging the system it shall be pressure tested with OFN. The system shall be leak tested on completion of charging but prior to commissioning. A follow up leak test shall be carried out prior to leaving the site.

### **14. Decommissioning**

Before carrying out this procedure, it is essential that the technician is completely familiar with the equipment and all its detail. It is recommended good practice that all refrigerants are recovered safely. Prior to the task being carried out, an oil and refrigerant sample shall be taken in case analysis is required prior to re-use of reclaimed refrigerant. It is essential that electrical power is available before the task is commenced.

a) Become familiar with the equipment and its operation.

b) Isolate system electrically.

c) Before attempting the procedure ensure that:

Mechanical handling equipment is available, if required, for handling refrigerant cylinders;

All personal protective equipment is available and being used correctly;

The recovery process is supervised at all times by a competent person;

Recovery equipment and cylinders conform to the appropriate standards.

d) Pump down refrigerant system, if possible.

e) If a vacuum is not possible, make a manifold so that refrigerant can be removed from various parts of the system.

f) Make sure that cylinder is situated on the scales before recovery takes place.

g) Start the recovery machine and operate in accordance with manufacturer's instructions.

h) Do not overfill cylinders. (No more than 80 % volume liquid charge).

i) Do not exceed the maximum working pressure of the cylinder, even temporarily.



## WARNINGS (for using R290/R32 refrigerant only)

- j) When the cylinders have been filled correctly and the process completed, make sure that the cylinders and the equipment are removed from site promptly and all isolation valves on the equipment are closed off.
- k) Recovered refrigerant shall not be charged into another refrigeration system unless it has been cleaned and checked.

### 15. Labeling

Equipment shall be labelled stating that it has been de-commissioned and emptied of refrigerant. The label shall be dated and signed. Ensure that there are labels on the equipment stating the equipment contains flammable refrigerant.

### 16. Recovery

When removing refrigerant from a system, either for servicing or decommissioning, it is recommended good practice that all refrigerants are removed safely.

When transferring refrigerant into cylinders, ensure that only appropriate refrigerant recovery cylinders are employed. Ensure that the correct number of cylinders for holding the total system charge is available. All cylinders to be used are designated for the recovered refrigerant and labelled for that refrigerant (i.e. special cylinders for the recovery of refrigerant). Cylinders shall be complete with pressure relief valve and associated shut-off valves in good working order. Empty recovery cylinders are evacuated and, if possible, cooled before recovery occurs.

The recovery equipment shall be in good working order with a set of instructions concerning the equipment that is at hand and shall be suitable for the recovery of flammable refrigerants. In addition, a set of calibrated weighing scales shall be available and in good working order. Hoses shall be complete with leak-free disconnect couplings and in good condition. Before using the recovery machine, check that it is in satisfactory working order, has been properly maintained and that any associated electrical components are sealed to prevent ignition in the event of a refrigerant release. Consult manufacturer if in doubt.

The recovered refrigerant shall be returned to the refrigerant supplier in the correct recovery cylinder, and the relevant Waste Transfer Note arranged. Do not mix refrigerants in recovery units and especially not in cylinders. If compressors or compressor oils are to be removed, ensure that they have been evacuated to an acceptable level to make certain that flammable refrigerant does not remain within the lubricant. The evacuation process shall be carried out prior to returning the compressor to the suppliers. Only electric heating to the compressor body shall be employed to accelerate this process. When oil is drained from a system, it shall be carried out safely.

# Installation Instructions

Installation  
Instructions

**NOTICE:** The unit you purchased may look like one of the followings:

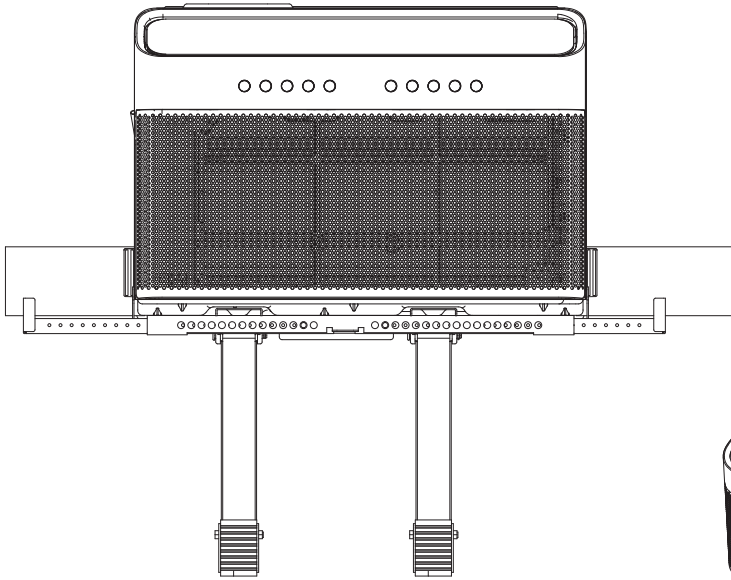

**Model A**

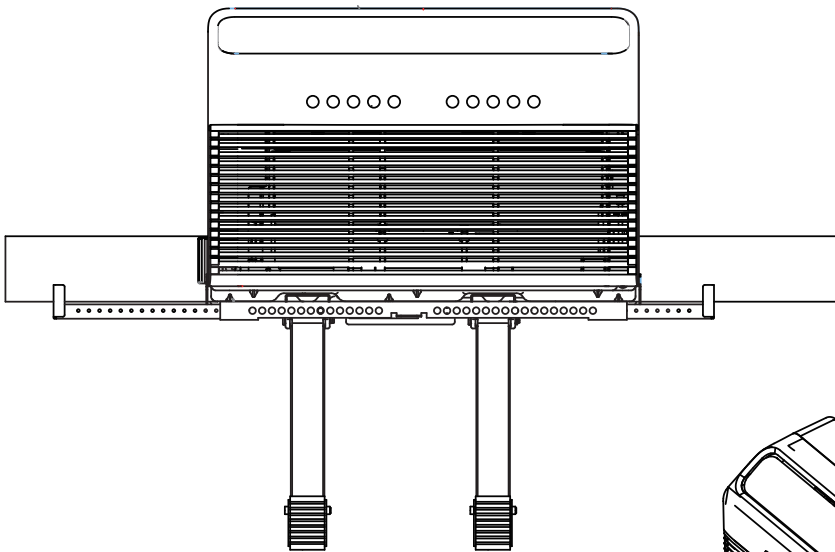
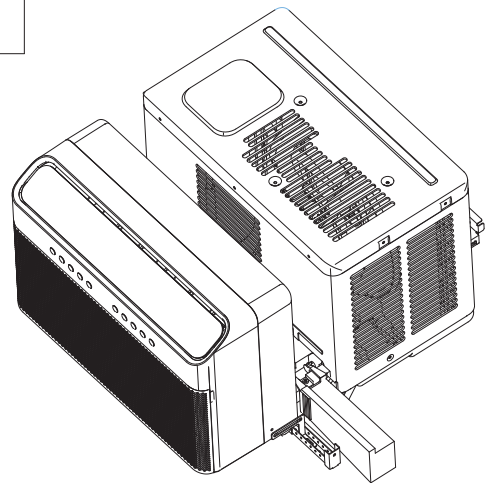

**Model B**

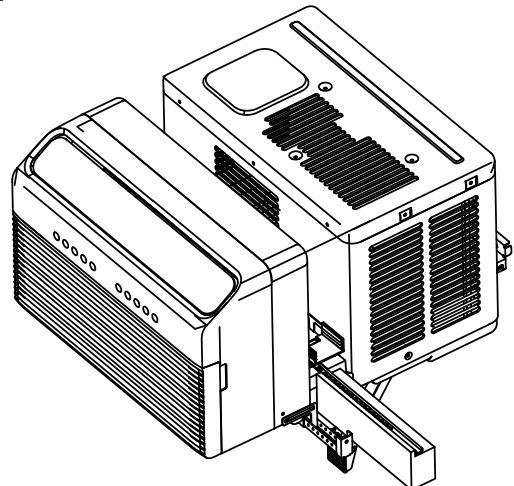

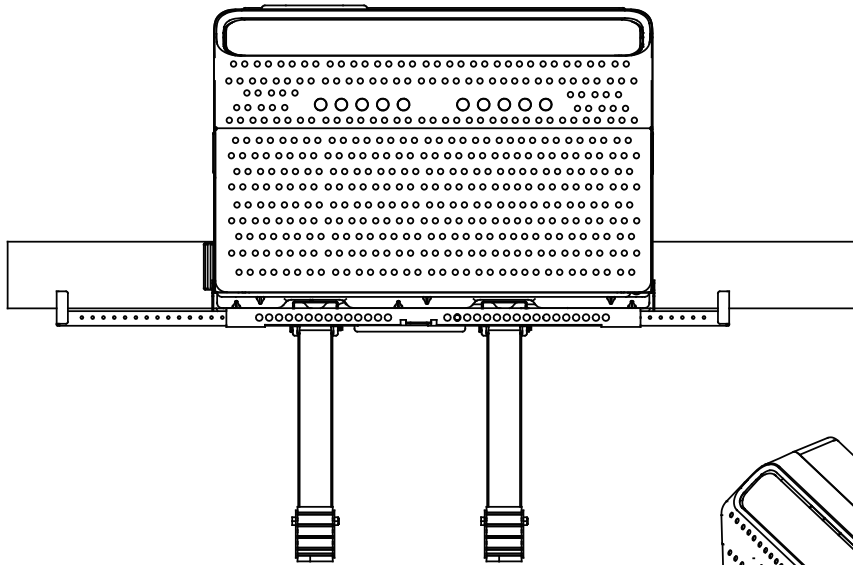

Model C

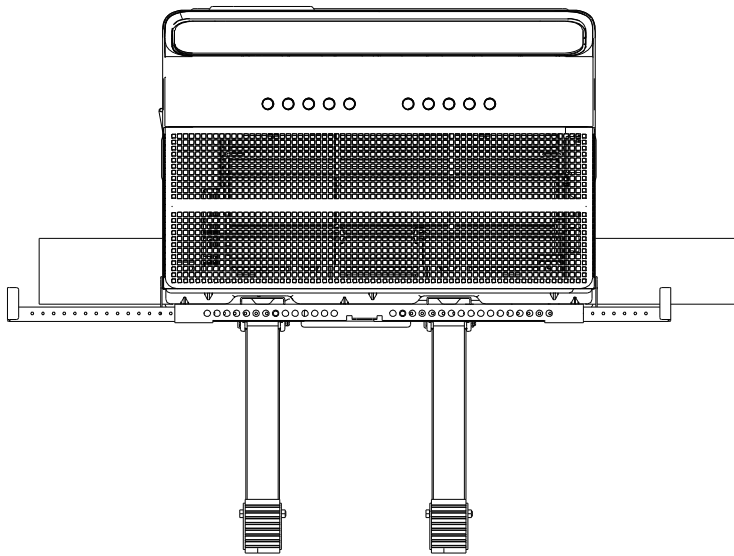
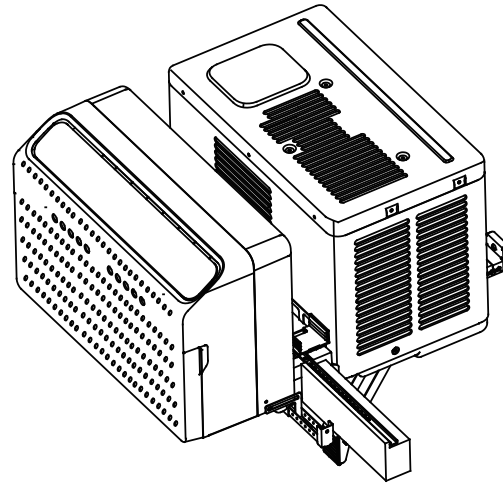

Model D

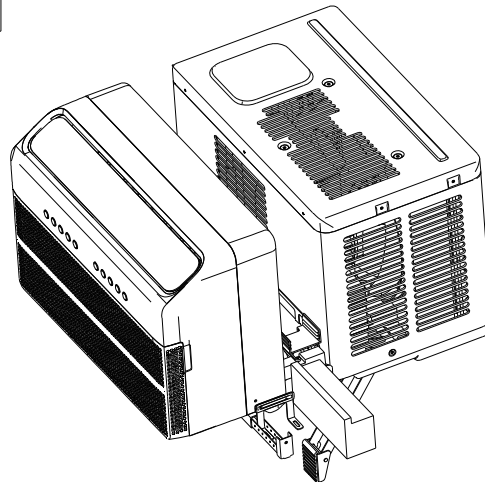

**NOTICE:**

All the illustrations in this manual are for explanation purpose only. The actual installation may vary.

**Installation Instructions**



**BEFORE YOU BEGIN**

Read these instructions completely and carefully.  
**IMPORTANT**-Save these instructions for local inspector's use.  
**IMPORTANT**-Observe all governing codes and ordinances.  
 Note to Installer- Be sure to leave these instructions with the Consumer.  
 Note to Consumer- Keep these instructions for future reference.  
 Skill level- Installation of this appliance requires basic mechanical skills.  
 Completion time- Approximately 1 hour.  
 We recommend that two people install this product.  
 Proper installation is the responsibility of the installer.  
 Product failure due to improper installation is not covered under the Limited Warranty.  
 You **MUST** use all supplied parts and use proper installation procedures as described in these instructions when installing this air conditioner.  
 Installation is recommended to be completed by 2 people.

**WINDOW-MOUNTED INSTRUCTIONS**

**! WINDOW REQUIREMENTS**

Your air conditioner is designed to install in standard double hung windows with opening widths of 22-36" (558mm-914mm) and a window height of 13.5" (343mm).

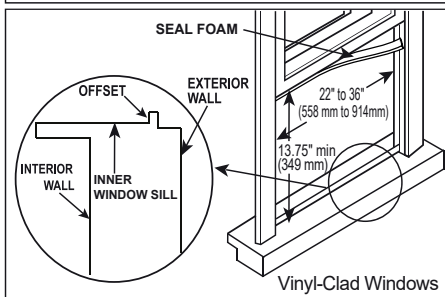
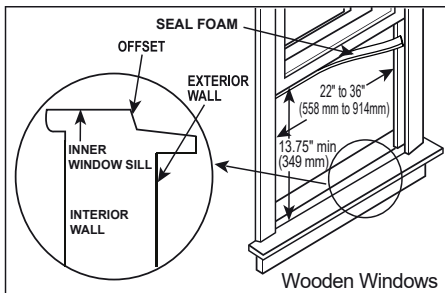

**! DANGER**

Do not, under any circumstances, cut or remove the third (ground) prong from the power cord.  
 Do not change the plug on the power cord of the air conditioner.  
 Aluminum house wiring may present special problems- consult a qualified electrician.  
 When handling the unit, be careful to avoid cuts from sharp metal edges and aluminum fins on front and rear coils.

**TOOLS YOU WILL NEED**

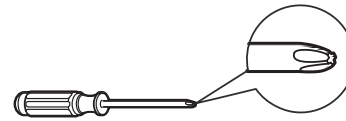

Phillips Screwdriver



Level



Flat Head Screwdriver



Pencil

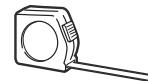

Ruler or tape measure

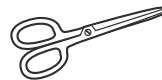

Scissors or knife

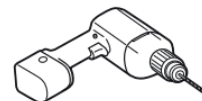

Drill and 1/8" drill bit



Proper PPE

Installation Hardware(on some models)

	1/2" Type B Screw	2*
	1/4" Type B Screw	2*
	Main Bracket	1
	Right Extension Arm (For 26"-36" windows)	1
	Right Extension Arm – Short (For 22"-26" windows)	1
	Main Support Pin	2*
	Cotter Pin	2*
	1/2" Type A Screw	3*
	Open Window Bracket – RH	1
	Open Window Bracket – LH	1
	Side Arm Foam	2

	Window Sash Lock	1
	Window Sash Foam	1
	Window Sealing Foam	1
	Bracket Sealing Foam	1
	Additional Side Arm Foam	2
	1" Type A Screw	2*

\* Denotes extra hardware provided in separate bag.

**NOTICE**

Save carton and these Installation Instructions for future reference. The carton is the best way to store unit during winter, or when not in use. If any piece of hardware is missing, DO NOT INSTALL THE PRODUCT, and call customer service.

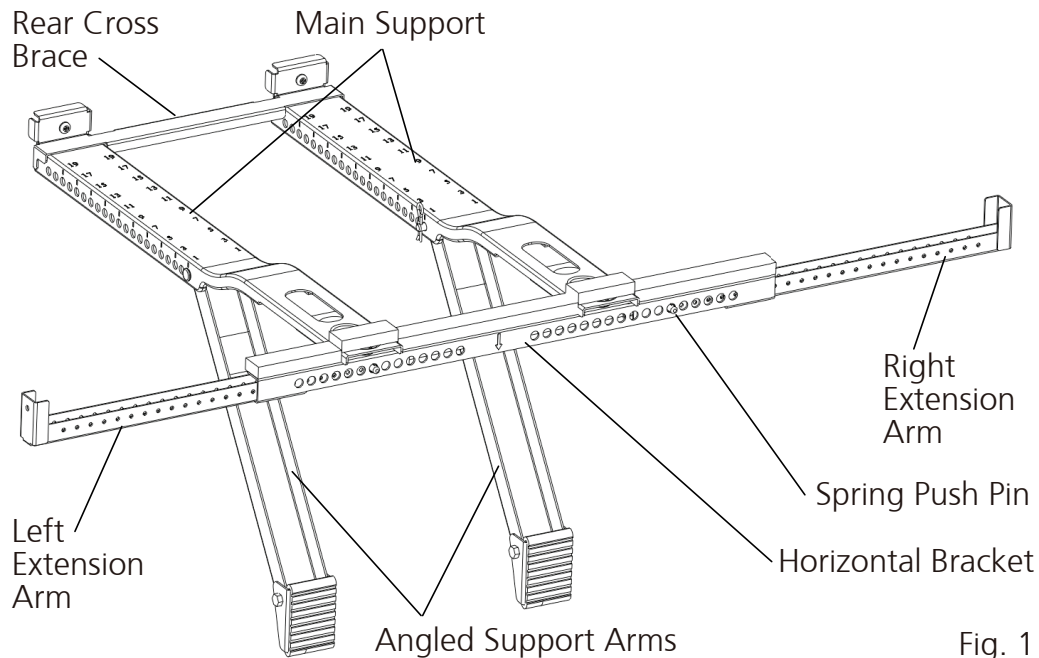

Fig. 1

**1. Prepare the Window**

Lower sash must open sufficiently to allow a clear vertical opening of 13.75 inches. Side louvers and the rear of the AC must have clear air space to allow enough airflow through the condenser for heat removal. The rear of the unit must be outdoors, not inside a building or garage. Find the center of your window and lightly mark with a pencil.

**2. Prepare the Bracket**

Remove the air conditioner, bracket and hardware from the carton and set on a flat surface.

Fig. 2

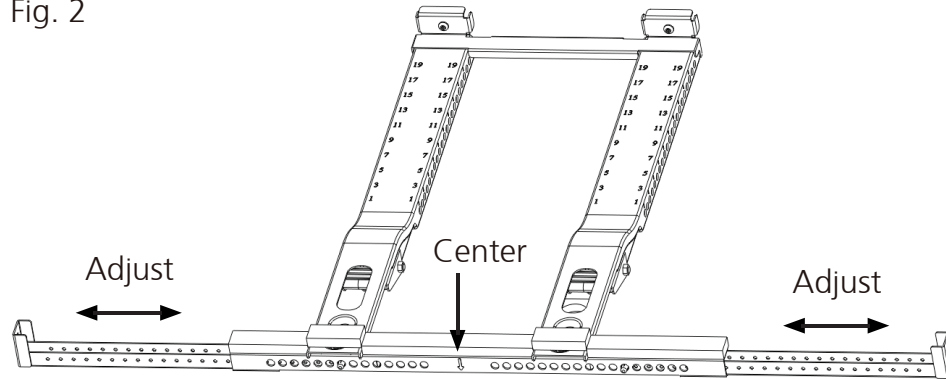

A. Pressing the Spring Push Pin, adjust the Left Extension Arm out and then install the Right Extension Arm.

Measure the width of the inner windowsill on your window. Making sure that the center of the bracket will line up with the center of the window, adjust the Extension Arms to the width just measured. Note, the bracket will be offset to the left when centered.

B. Apply Bracket Sealing Foam strips to the bottom of the bracket as shown.

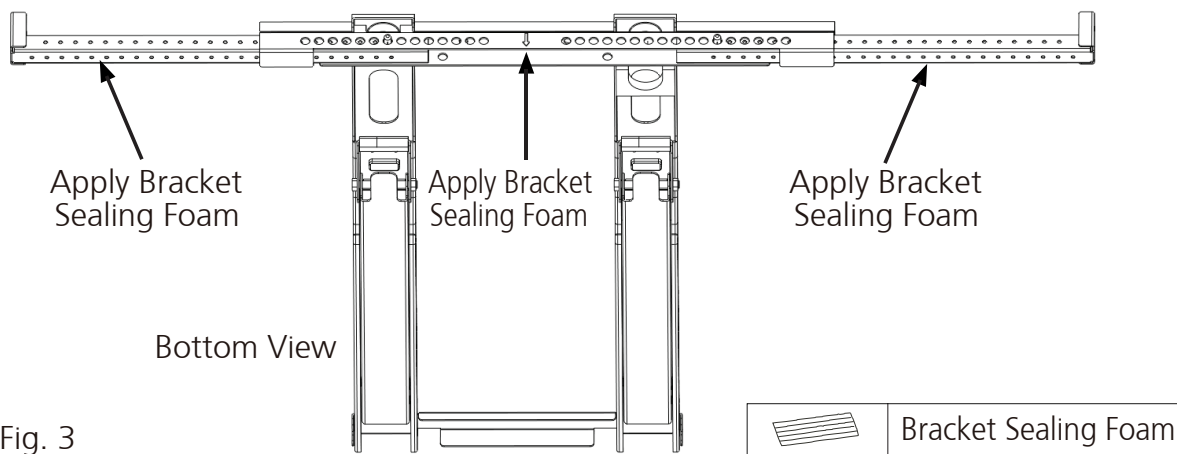

Fig. 3

**3. Install Support Bracket**

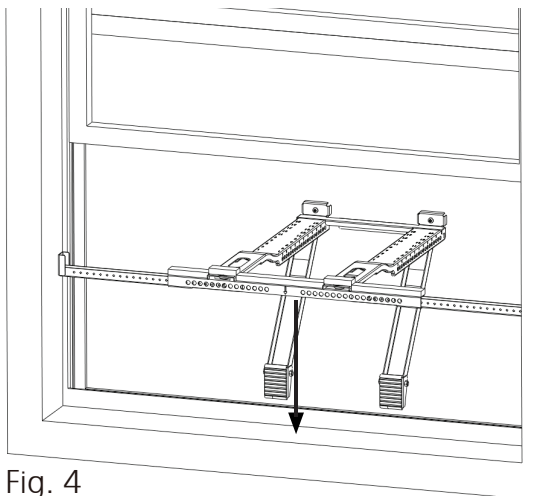

Fig. 4

A. Install the Main Support Bracket into the window opening. Ensure that the Horizontal Bracket and Extension Arms are located on the indoor side of the window.

**! WARNING**

Maintain control of the bracket until installation is complete.

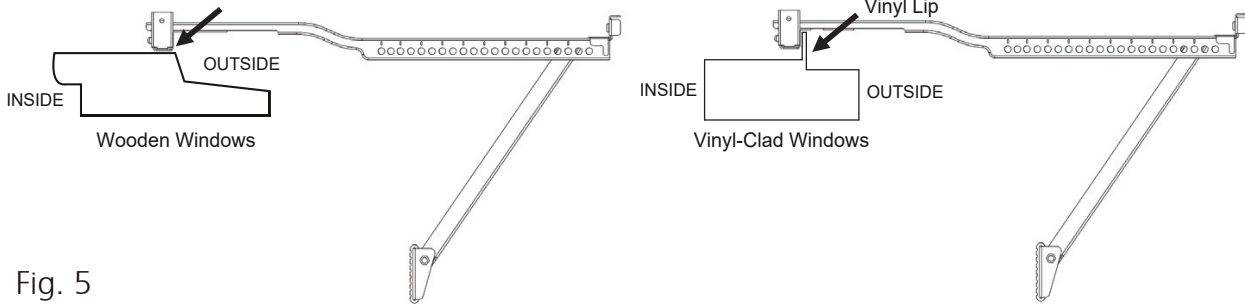

Fig. 5

Vinyl Type Windows with a Lipped Sill

A1. Secure the bracket to the windowsill by drilling 1/8" pilot holes and installing the 1/2" Type A screws as shown in Fig. 6.

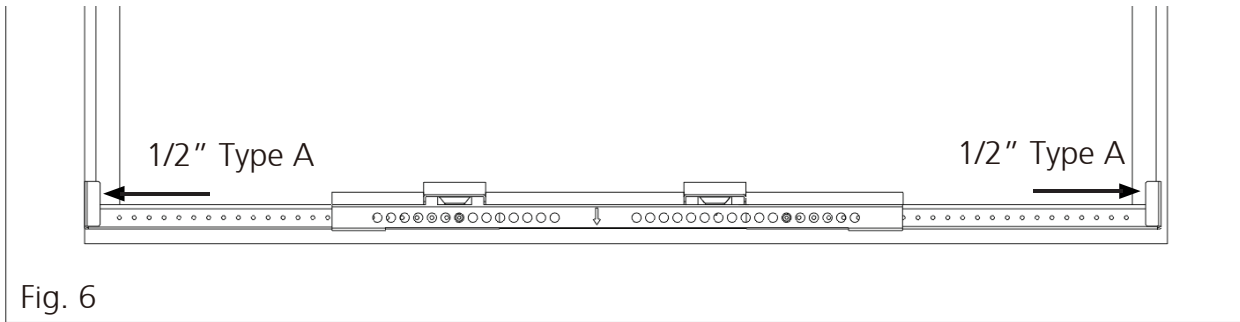

Fig. 6

Wooden Type Windows with a Flat Sill

A2. Secure the bracket to the windowsill by drilling 1/8" pilot holes and installing the 1/2" and 1" Type A screws as shown in Fig. 7.

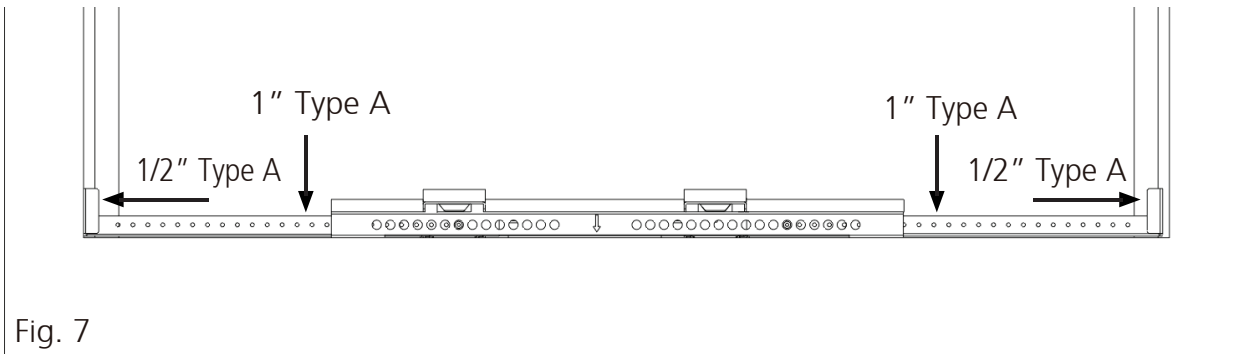

Fig. 7

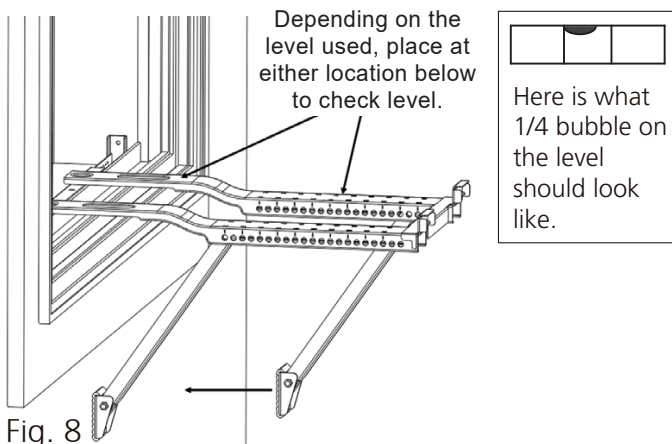

Fig. 8

B. Move the Angled Support Arms toward the exterior wall until the feet touch the wall. Place the level on the bracket and adjust the Support Arms so that it is level or tilted 1/4 bubble downward and towards the outside.



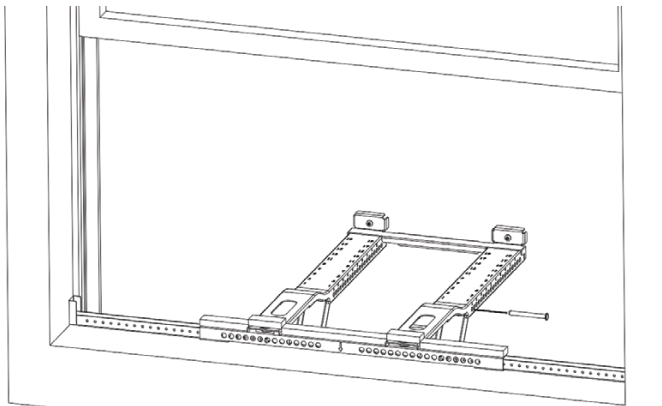
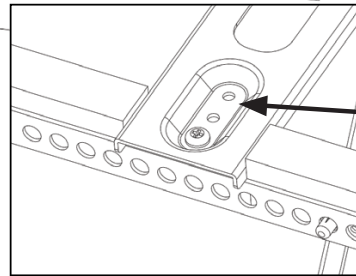

Fig. 9

C. Insert the Main Support Pin through the holes the Main Support and Angled Support Arm. Using the numbers on the Main Support, repeat the adjustment for the other Angled Support Arm matching the hole number from the first support arm.



If further adjustment is needed, use alternate holes where the Main Supports attach to the Horizontal Bracket

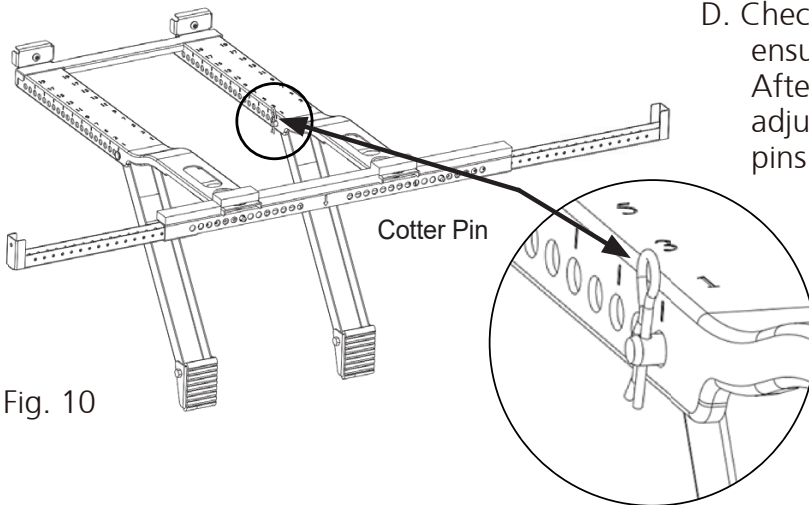

Fig. 10

D. Check the level again and ensure the bracket feels secure. After making any necessary adjustments, insert the cotter pins into the Main Support Pins.

E. If necessary, cover the holes on the front of the bracket with the Bracket Sealing Foam.

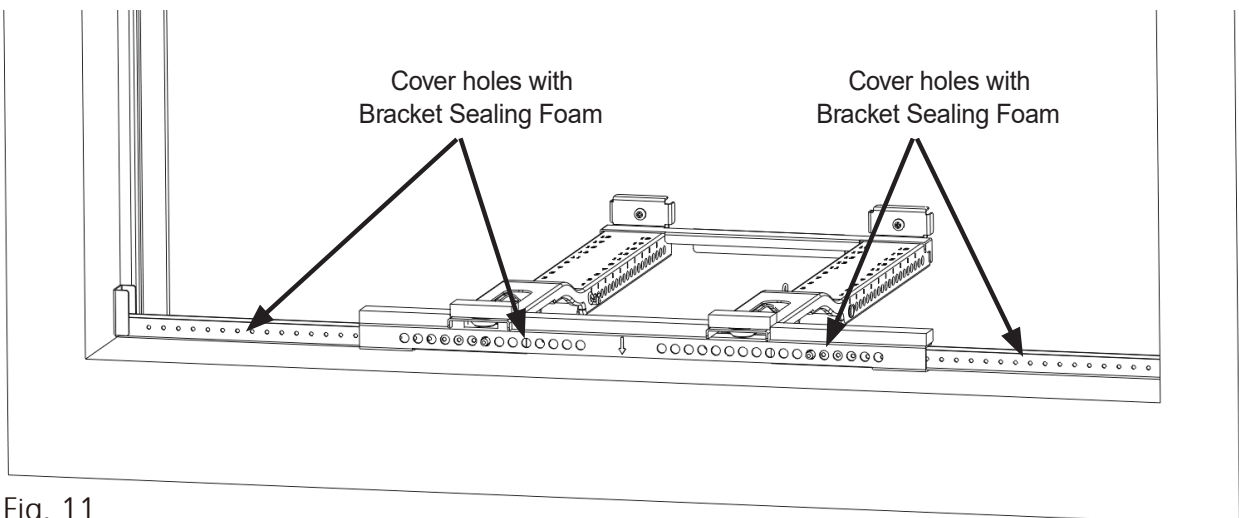

Fig. 11



## 4. Install Air Conditioner

### NOTICE

Measure the width of your window track (the vertical track your window slides up and down in) before installing your air conditioner. If it measures 1/2" or less, flip the Anti-Tip Bracket so the smooth end faces out, then continue with your air conditioner installation.

- A. Set the air conditioner on top of the support bracket. Ensure the grooves on the bottom of the air conditioner align with the Main Supports. Using a level, check for proper tilt towards the outside.

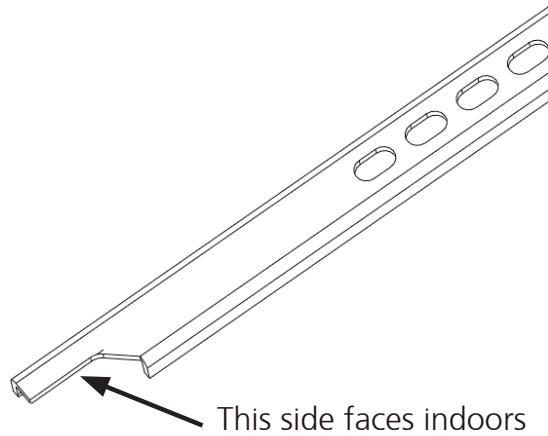

### ⚠ WARNING

Do not leave the unit unattended during installation.

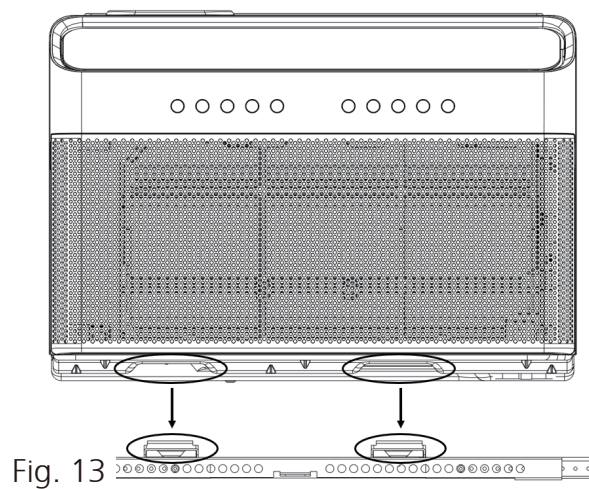
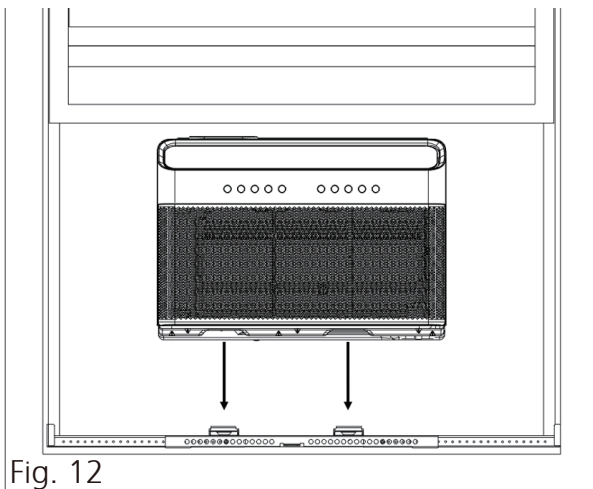

- B. Pull the window down into the slot to help align the unit in the correct location. Keep the window partially inserted into the window slot to help support the air conditioner during installation.

Fold down both Side Arm Hinges.

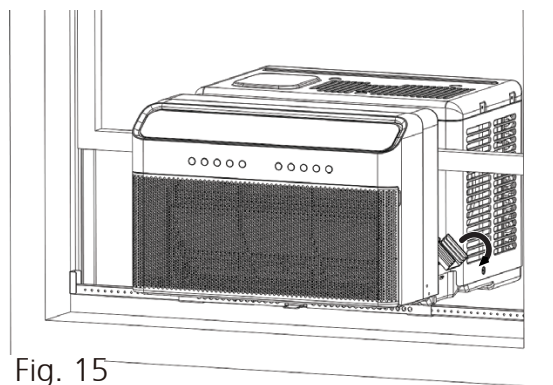
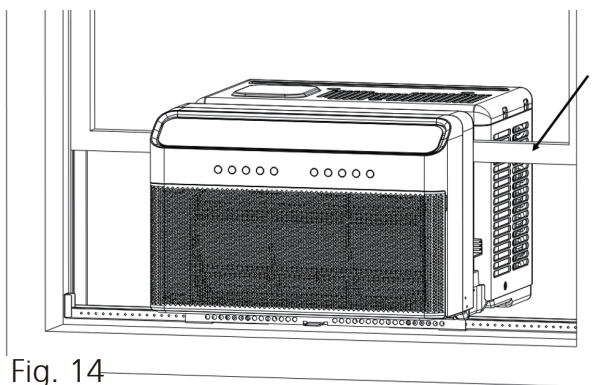

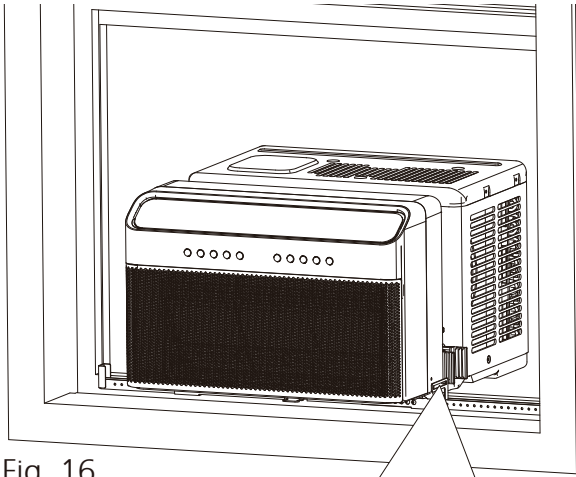
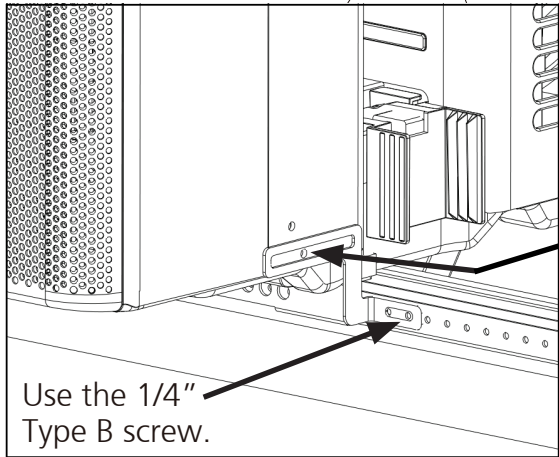

Fig. 16

C. Next, you must install the Open Window Brackets using the provided screws as shown.



Use the 1/2" Type B screw.

Use the 1/4" Type B screw.

**! WARNING**

Failing to install the Open Window Brackets could cause injury or property damage.

**5. Foam Installation**

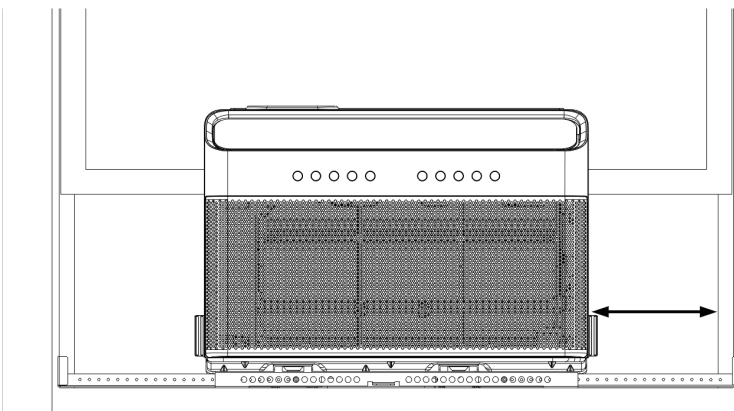

Fig. 17

A. Measure the distance between the Side Arm Hinge and the closest part of the window frame in line with the Side Arm.

Add 1/4" to this distance and cut the Side Arm Foam to length.

**! WARNING**

Do not leave the unit unattended during installation.

B. Apply Window Sealing Foam to the Side Arm Foam as shown. Note that the Window Sealing Foam attaches to the side next to the air conditioner.

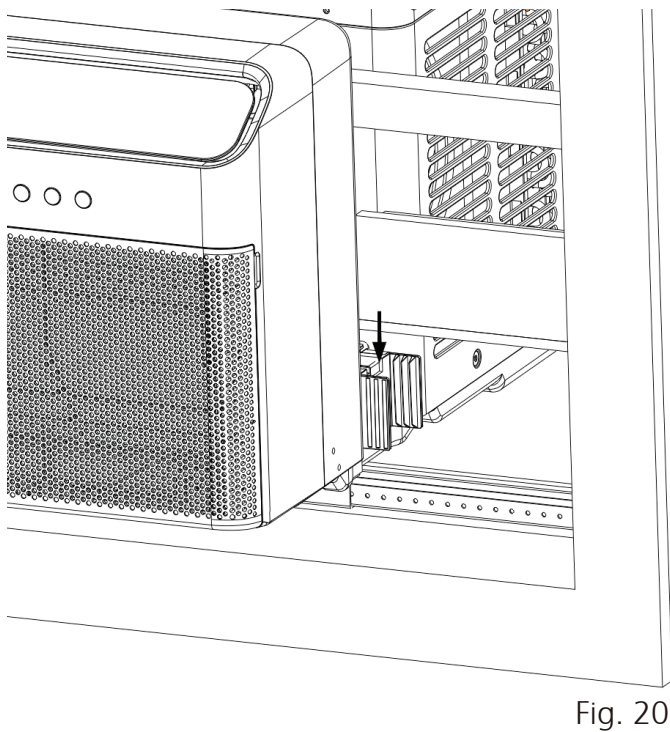
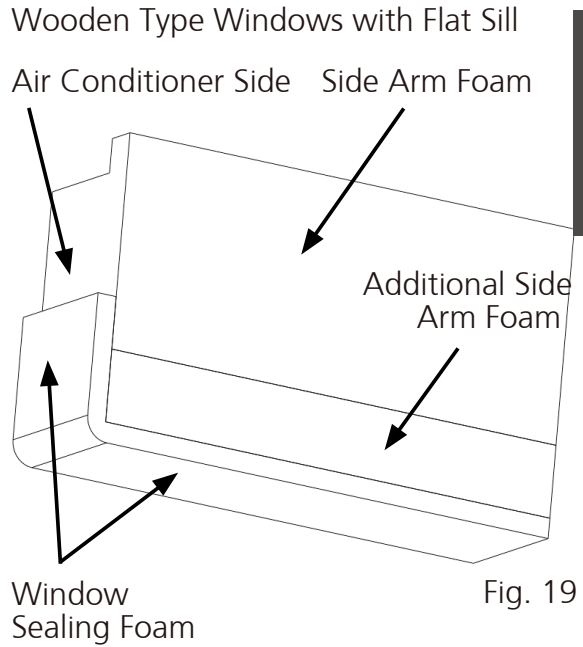
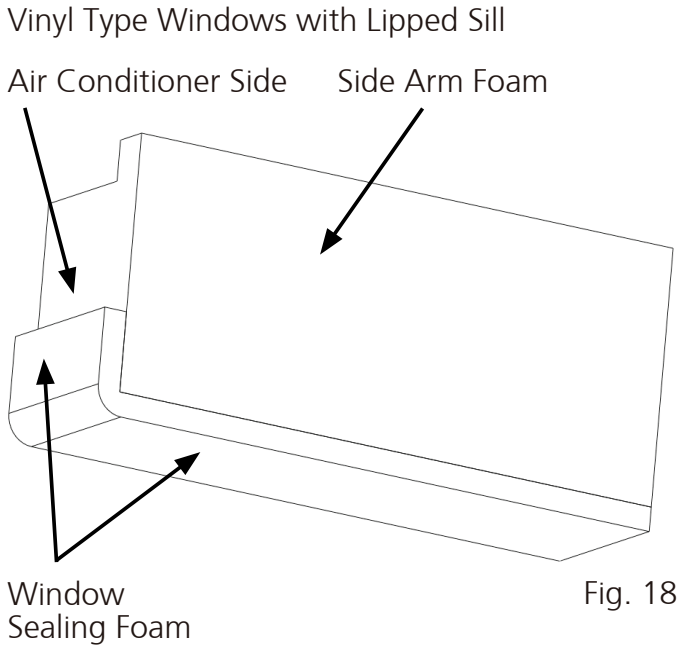

C. Insert Side Arm Foam into Side Arm Hinge until the top front of the Side Arm is flush with the top of the hinge.

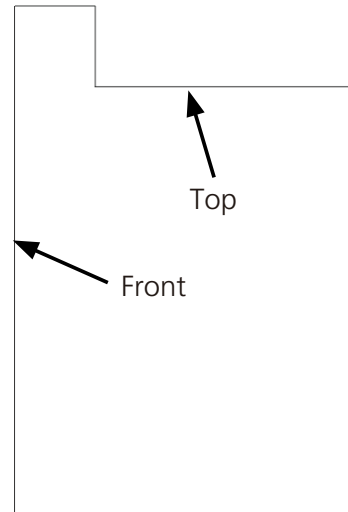

**NOTICE**

Repeat the side arm foam installation steps on the other side of the unit as well.

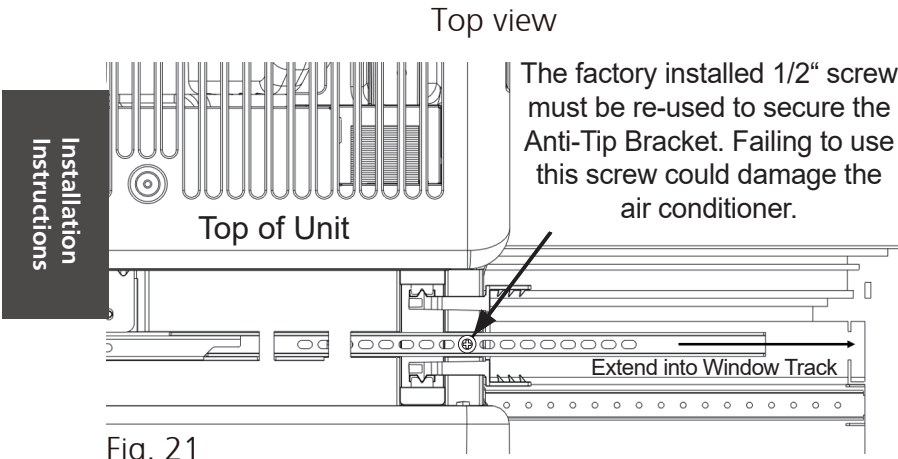

Fig. 21

D. The Anti-Tip Brackets must be extended into the window track opening (the vertical track your window slides up and down in) until they stop. Secure the brackets in place by using the provided 1/2" Phillips head screw.

**! WARNING**

You must extend the Anti-Tip Brackets into the Window Track Opening. Failure to follow this warning may cause serious injury.

The images below show how the Anti-Tip Bracket is to be installed in the window track. Note the Side Arm Foam was removed for illustration purposes only.

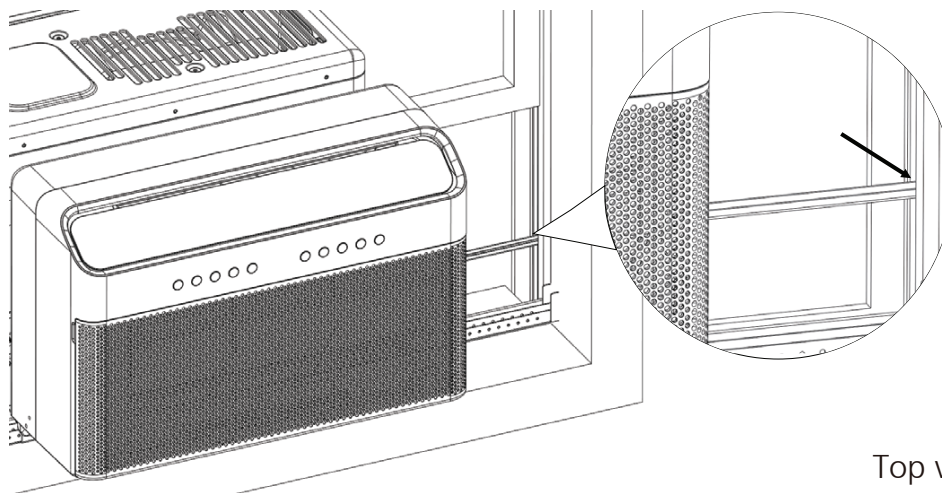

Fig. 22

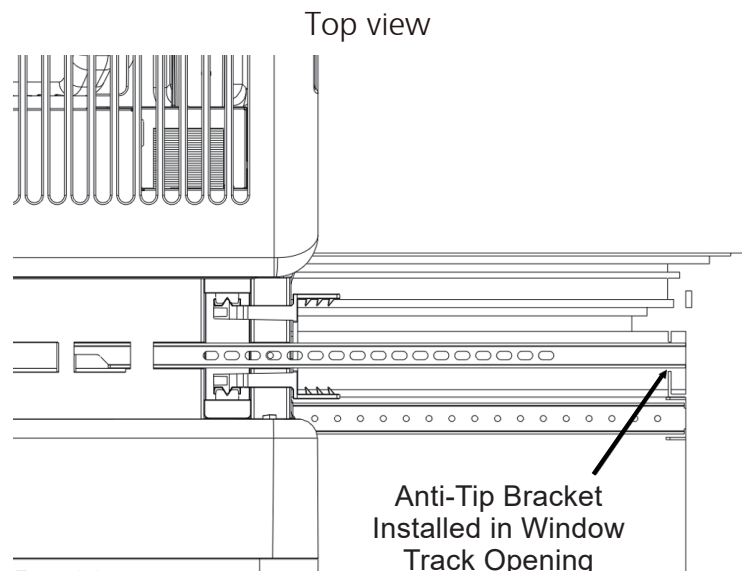

Fig. 23

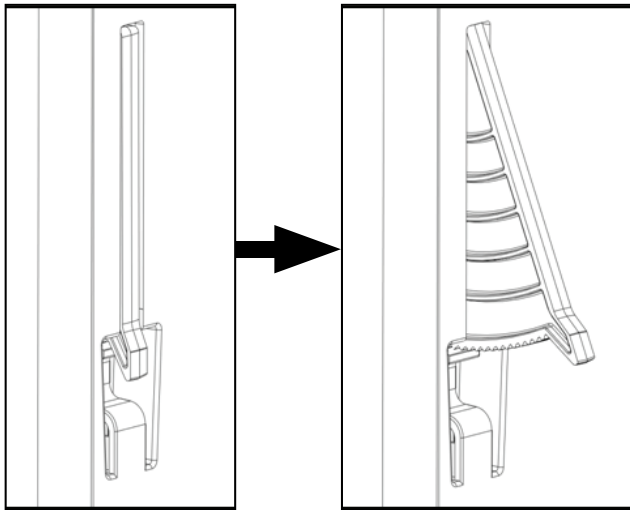

Fig. 24

- E. Install a strip of Window Sealing Foam to the bottom of your lower sash sealing any small gaps between the window and air conditioner. Then close the window and check for gaps. Fill any gaps with the included foam as needed.
- F. Extend the Integrated Window Locks (located in the U channel) until they contact the window. For additional security you can install the optional Sash Lock as shown.



Fig. 25

- G. To secure the lower sash in place, attach right angle sash lock with 1/2" Type A Screws as shown.

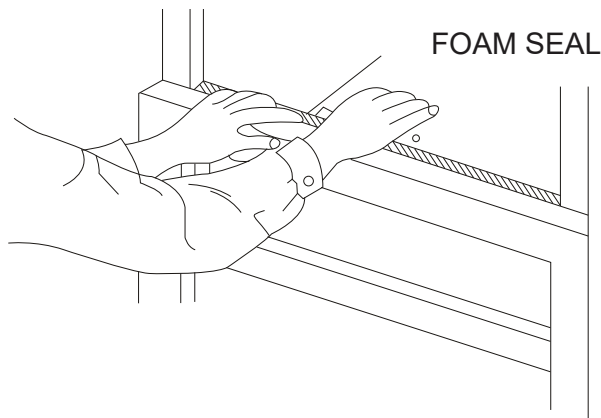
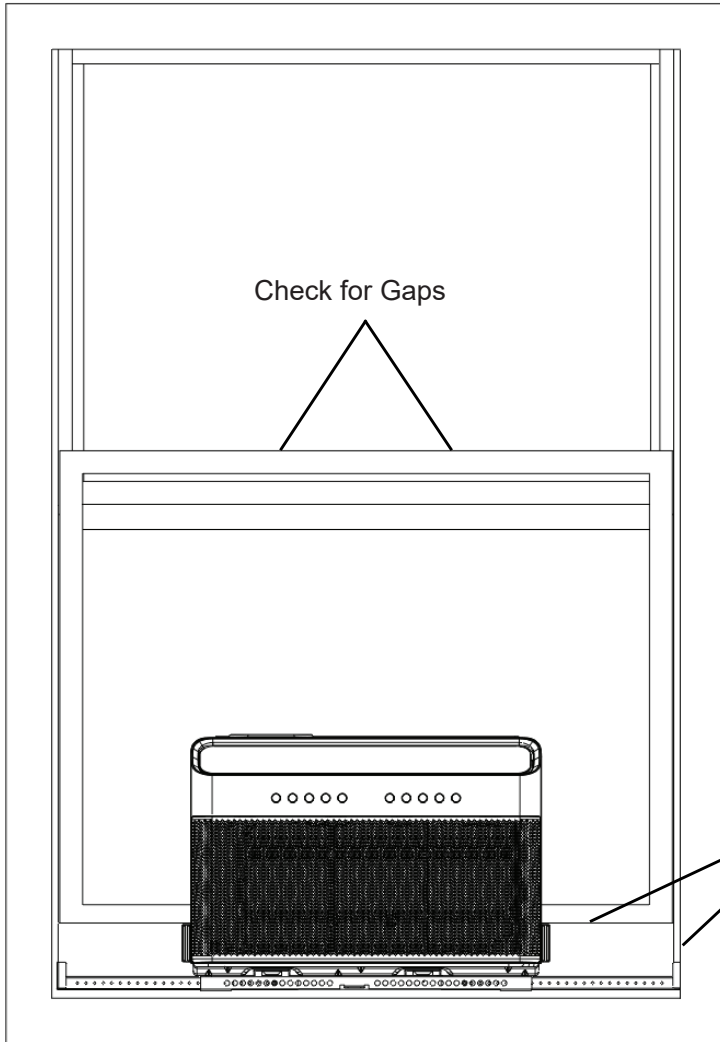

Fig. 26

- H. Cut window sash foam and insert it in the space between the upper and lower sashes.



**Installation Instructions**



Final Check: Review the installation and check for any gaps or openings to the outdoor air. Cover these gaps with the provided foam ensuring no outdoor air leaks inside. See image for areas to check for gaps.

Fig. 27

**IF AC IS BLOCKED BY STORM WINDOW**

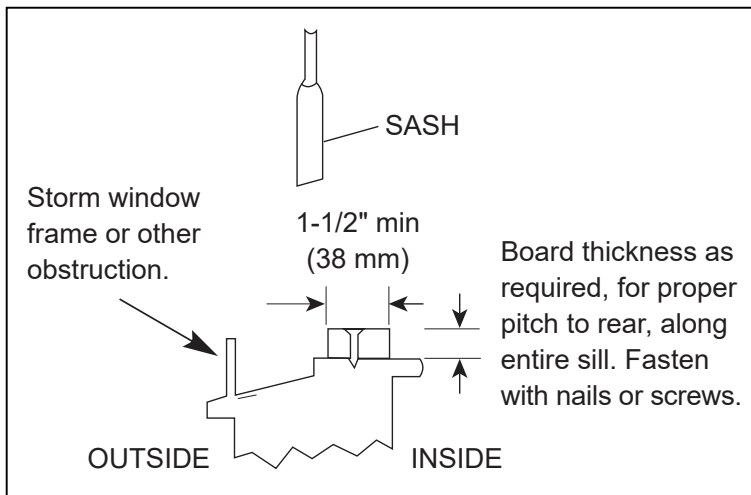

Add wood as shown, or remove storm window before air conditioner is installed. If storm window frame must remain, be sure the drain holes or slots are not caulked or painted shut. Accumulated rain water or condensation must be allowed to drain out. You must secure the support bracket to the added wood piece using the provided 1" Type A Screws. Refer to the Open Window Bracket installation step.

Fig. 28



## WALL-MOUNTED INSTRUCTIONS

**Note:** Remove the air conditioner and hardwares from the carton and place on a flat surface. Save Carton and these Installation Instructions for future reference. The carton is the best way to store unit during winter, or when not in use.

### Suggested tools

1. Screw driver (medium size Phillips)
2. Tape measure or ruler
3. Knife or scissors
4. Level gaug

### Hardware(Packed with the unit)

	Window sash seal foam	1
	Weather stripping (10*3/4" *1/12")	1
	Sealed sponge	2
	Open Window Bracket – RH	1
	Open Window Bracket – LH1	1
	Owner's Manual	1set

### Select the best location

1. To avoid vibration and noise, make sure the unit is installed securely and firmly.
2. Install the unit where the sunlight does not shine directly on the unit. If the unit receives direct sunlight, build an awning to shade the cabinet.
3. There should be no obstacle, such as a fence or wall, within 50cm from the back of the cabinet because it will prevent heat radiation of the condenser. Restriction of outside air will greatly reduce the cooling and heating efficiency of the air conditioner.
4. Install the unit a little obliquely outward not to leak the condensed water into the room (about 3~4 Owith level).
5. Install the unit with its bottom portion 75~150cm above the floor level.
6. The power cord must be connected to an independent circuit. The yellow/green wire must be grounded.

## CAUTION

All side louvers of the cabinet must remain exposed to the outside of the structure.

**Note:** After installing, make sure the air conditioner is tilted 3~4° to the outside to allow water drainage and perfect cooling efficiency.

### Select the best location

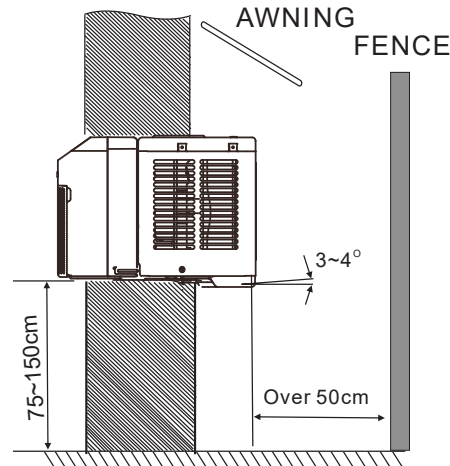

Note: Unit may be supported by a solid frame from below or by a hanger from a solid overhead support.

Installation Instructions

### Installations of the unit into the wall

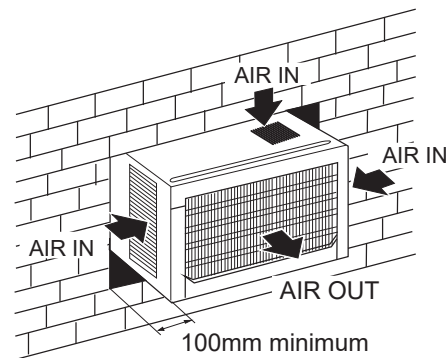

OPTION A

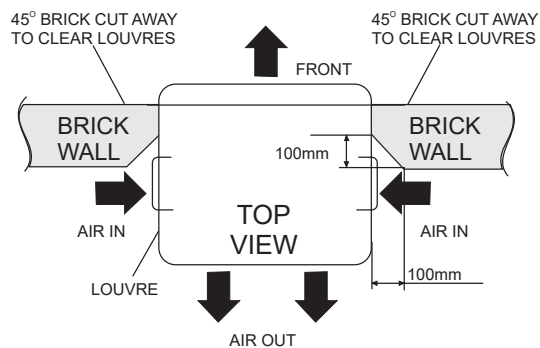

OPTION B

# Normal Sounds

Normal Sounds/  
Sound Performance

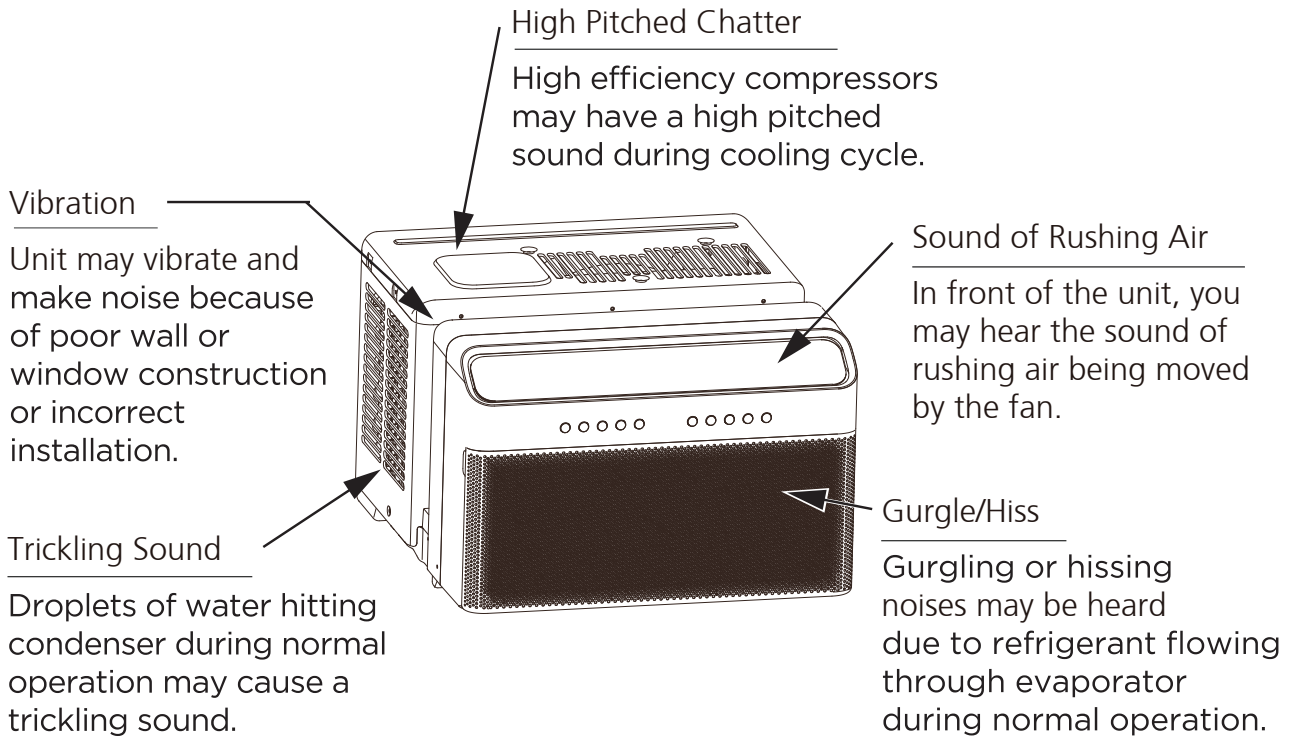

**NOTICE**

All the illustrations in this manual are for explanation purpose only. The actual installation may vary.



## Air Conditioner Features

### ⚠ WARNING

To reduce the risk of fire, electrical shock, or injury to people or property, read the SAFETY PRECAUTIONS before operating this appliance.

Cooling Operation	Outdoor temp.: 64°F ~ 109°F / 18°C ~ 43°C
	Indoor temp.: 60°F ~ 90°F / 16°C ~ 32°C

### NOTICE

- The relative humidity of the room should be less than 80%. If the unit is used in a condition with a relative humidity over 80%, there will be condensed water on the surface of the unit.
- Performance may be reduced outside of these operating temperatures.

### NOTICE

Always wait 3 minutes when turning the unit off and then on again, or when changing from cool to fan and back to cool. This prevents damage from occurring to the compressor.

To begin operating the air conditioner, follow these steps:

1. Plug in the air conditioner (be sure to follow the power cord instructions).
2. Turn the power on to the air conditioner, using the ON/OFF button.
3. Set the thermostat to the coldest temperature setting.
4. Select the Cool mode setting.
5. Adjust the louver for comfortable air flow (see Air Directional Louvers).
6. Once the room has cooled, adjust the thermostat to the setting you find most comfortable.
7. Make sure the air flow inside and outside is not obstructed by anything.

### Air Directional Louvers

The louvers will allow you to direct the air flow up or down (on some models) and left or right throughout the room as needed. Use the SWING button until the desired up/down direction is obtained.

Move the louvers from side to side until the desired left/right direction is obtained.

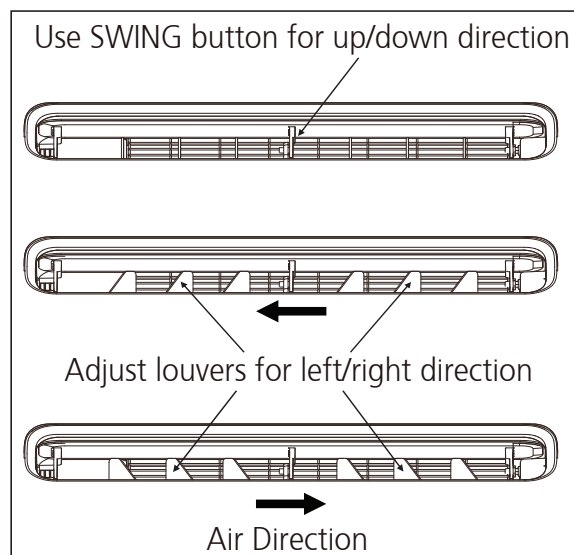

## ELECTRONIC CONTROL OPERATING INSTRUCTIONS

### NOTICE:

Different models have different control buttons and indicator lights. Not all the control buttons and indicator lights describing below are available for the unit you purchased. Please check the control panel of the unit you purchased.

**The unit can be controlled by the unit control or with the remote.**

Air Conditioner Features

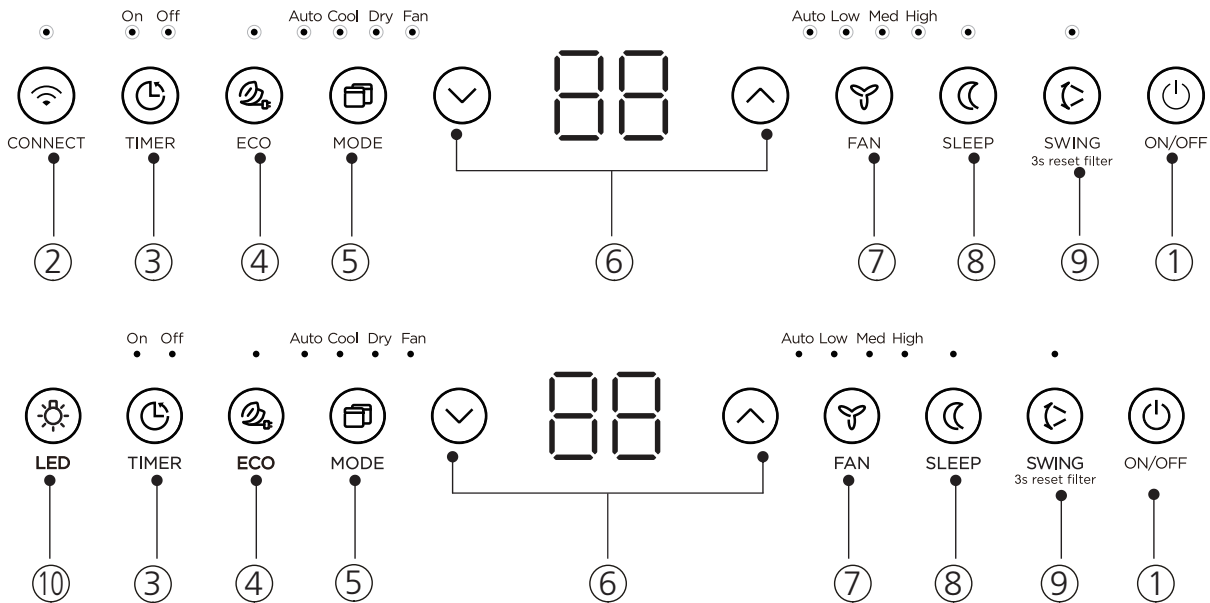

### Operation buttons

- ① **ON/OFF:** Press button to turn unit on or off.  
NOTE: The unit will automatically initiate the Energy Saver function under cool, Dry, and Auto modes.
  
- ② **CONNECT** button: For the first time to use WiFi function, press the button for 3 seconds to initiate the WiFi connection mode. The LED DISPLAY shows 'AP' to indicate you can set WiFi connection. If connection(router) is successful within 8 minutes, the unit will exit WiFi connection mode automatically and the CONNECT indicator illuminates. If connection is failure within 8 minutes, the unit exits WiFi connection mode automatically. After WiFi connection is successful, you can press and hold CONNECT and DOWN ( ) buttons at the same time for 3 seconds to turn off WiFi function and the LED DISPLAY shows 'OF' for 3 seconds, press CONNECT and UP( ) buttons at the same time to turn on WiFi function and the LED DISPLAY shows 'ON' for 3 seconds.
  
- ③ **TIMER** button
  - Press Timer button, the TIMER ON or TIMER OFF indicator light illuminates. It indicates the Auto Start or Auto Stop program is initiated. For some units, continuing to press the Timer button will cancel the timer settings.
  - Press or hold the UP or DOWN button to change the Auto time by 0.5 hour increments, up to 10 hours, then at 1 hour increments up to 24 hours. The control will count down the time remaining until start.

- The selected time will register in 5 seconds, and the system will automatically revert back to display the previous temperature setting or room temperature when the unit is on. When the unit is off, there is no display.
- Turning the unit ON or OFF at any time or adjusting the timer setting to 0.0 will cancel the Auto Start/Stop timed program.

#### ④ ECO button

Press ECO button to initiate this function. This function is available on COOL, DRY, and AUTO (only AUTO-COOLING and AUTO-FAN) modes. The fan will continue to run for 3 minutes after the compressor shuts off. The fan then cycles on for 2 minutes at 10 minute intervals until the room temperature is above the set temperature, at which time the compressor turns back on and Cooling Starts.

#### ⑤ MODE button

To choose operating mode, press the MODE button. Each time you press the button, a mode is selected in a sequence that goes from Auto, Cool, Dry and Fan. The indicator light beside the button will be illuminated and will remain on once that mode is selected.

The unit will automatically initiate the Energy Saver function under Cool, Dry, and Auto (only Auto-Cooling and Auto-Fan) modes.

1. To operate on Auto feature :

- When you set the air conditioner to Auto mode, it will automatically select cooling or fan only operation, depending on what temperature you have selected and the current room temperature.
- The air conditioner will control the room temperature automatically based on the temperature you set.
- In this mode, the fan speed cannot be adjusted, it starts automatically at a speed according to the room temperature.

2. To operate on COOL mode :

- Choose Cool Mode to set the cooling function. Use the Up and Down buttons to choose the desired temperature. When Cool Mode is selected, the fan speed can be adjusted by pressing the fan button.



3. To operate on Dry mode :



- In this mode, the air conditioner will generally operate as a dehumidifier. Since the conditioned space is a closed or sealed area, some degree of cooling will continue. On Dry mode, the fan speed is not adjustable.

4. To operate on Fan Only :

- Use this function only when cooling is not desired, such as for room air circulation or to exhaust stale air (on some models). (Remember to open the vent during this function, but keep it closed during cooling for maximum cooling efficiency.) You can choose any fan speed you prefer.
- In Fan only mode, the temperature is not adjusted.

#### ⑥ button

Press  or  button to change temperature setting.

NOTE: Press or hold either  or  button until the desired temperature is shown on the display.

This temperature will be automatically maintained anywhere between 60°F (16°C) and 86°F (30°C).

If you want the display to read the actual room temperature, see "To Operate on Fan Only" section."

#### ⑦ FAN button

Press Fan button to select the Fan Speed in four steps-Auto, Low, Med or High. Each time the button is pressed, the fan speed mode is shifted. For some models, the fan speed can not be adjusted.

- ⑧ **SLEEP** button  
 Press Sleep button to initiate the sleep mode. In this mode the selected temperature will increase (in cooling mode) by 2°F/1 (or 2)°C 30 minutes after the mode is selected. The temperature will then increase (in cooling mode) by another 2°F/1 (or 2)°C after an additional 30 minutes. This new temperature will be maintained for 7 hours before it returns to the originally selected temperature. This ends the Sleep mode and the unit will continue to operate as originally programmed. The Sleep mode program can be cancelled at any time during operation by pressing the Sleep button again.
  
- ⑨ **SWING** button  
 Used to initiate the Auto swing feature. When the operation is ON, pressing the SWING button can stop the louver at the desired angle.  
 Press SWING button for 3 seconds to initiate the filter feature. This feature is a reminder to clean the Air Filter for more efficient operation. The LED(the light above the button) will illuminate after 250 hours of operation.
  
- ⑩ **LED** button
  - Press LED button to turn the LED display on and off, which create a comfortable environment.

**DISPLAYS**

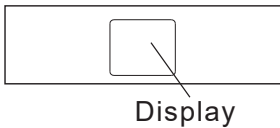

**DISPLAYS:**

Shows the set temperature in " °C " or " °F " and the Auto-timer settings. While on Fan only mode, it shows the room temperature. If the room temperature is too high or low, it will display " HI " or " LO ".The control is capable of displaying temperature in degrees Fahrenheit or degrees Celsius. To convert from one to the other, press and hold the Up and Down buttons at the same time for 3 seconds.

**Error codes:**

The unit may stop operation or continue to run safely. If the error codes appear, wait for about 10 minutes. The problem may resolve itself. If not, disconnect the power, then connect it again. Turn the unit on. If the problem persists, disconnect the power and contact your nearest customer service center. Error code appears and begins with the letters as the following in the window display of indoor unit: EH(xx), EL(xx), EC(xx) , PH(xx), PL(xx), PC(xx).

**NOTICE:** If your problem persists after performing the checks and diagnostics above, turn off your unit immediately and contact an authorized service center.

**📌 NOTICE:**

If the unit turns off unexpectedly due to the power being cut, it will automatically restart with the previous function setting when the power resumes.

**ADDITIONAL THINGS YOU SHOULD KNOW**

Now that you have mastered the operating procedure, here are more features in your control that you should become familiar with.

- The Cool circuit has an automatic 3 minutes time delayed start if the unit is turned off and on quickly. This prevents overheating of the compressor and possible circuit breaker tripping. The fan will continue to run during this time.

## Care and Cleaning

### ⚠ CAUTION

Clean your air conditioner occasionally to keep it looking new. Be sure to unplug the unit before cleaning to prevent shock or fire hazards.

### Air Filter Cleaning

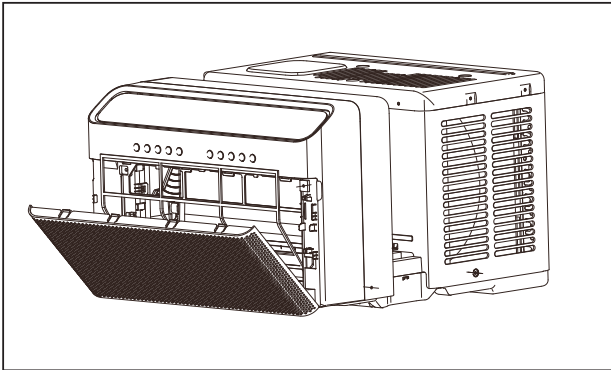

The air filter should be checked at least once every two weeks to see if cleaning is necessary. Trapped particles in the filter can build up and cause an accumulation of frost on the cooling coils and reduce performance.

- Push the vent handle to the Vent Closed position (where applicable). Open the front panel.
- Take the filter by the center and pull up and out.
- Wash the filter using warm water. Rinse filter thoroughly. Gently shake excess water from the filter. Be sure the filter is thoroughly dry before replacing. Instead of washing, you may vacuum the filter clean.

### 📌 NOTICE:

Never use hot water over 104°F (40°C) to clean the air filter. Never attempt to operate the unit without the air filter.

### Cabinet Cleaning

Be sure to unplug the air conditioner to prevent shock or fire hazard. The cabinet and front may be dusted with an oil-free cloth or washed with a cloth dampened in a solution of warm water and mild liquid dishwashing detergent. Rinse thoroughly and wipe dry.

Never use harsh cleaners, wax or polish on the cabinet front. Be sure to wring excess water from the cloth before wiping around the controls. Excess water in or around the controls may cause damage to the air conditioner. Plug in air conditioner.

### Winter Storage

If you plan to store the air conditioner during the winter, remove it carefully from the window according to the installation instructions. Be careful not to spill any potentially standing water from the unit's base pan. If water is present, carefully drain it. Cover the unit with plastic or return it to the original carton.

## TROUBLESHOOTING TIPS

Before calling for service, review this list. It may save you time and money. This list includes common occurrences that are not the result of defective workman-ship or materials in this appliance.

Problem	Solution
<b>Air conditioner does not start</b>	Wall plug disconnected. Push plug firmly into wall outlet.
	House fuse blown or circuit breaker tripped. Replace fuse with time delay type or reset circuit breaker.
	Plug Current Device Tripped. Press the RESET button.
	Power is OFF. Turn power ON.
<b>Air from unit does not feel cold enough</b>	Room temperature below 60°F(16°C). Cooling may not occur until room temperature rises above 60°F(16°C).
	Temperature sensor behind the air filter is touching the cold coil. Try to move it so it does not contact the cold coil.
	Set to a lower temperature.
	Compressor stopped when changing modes. Wait for 3 minutes after set to the COOL mode
	Check for potential obstructions blocking the outdoor intake/exhaust. Clear any obstructions.
<b>Air conditioner cooling, but room is too warm- ice forming on cooling coil behind air filter.</b>	Outdoor temperature below 64°F(18°C). To defrost the coil, set FAN ONLY mode.
	Air filter may be dirty. Clean filter. Refer to Care and Cleaning section. To defrost, set to FAN ONLY mode.
	Thermostat set too cold for night-time cooling. To defrost the coil, set to FAN ONLY mode. Then, set temperature to a higher setting.
<b>Air conditioner cooling, but room is too warm- NO ice forming on cooling coil behind air filter.</b>	Dirty or restricted air filter. Clean air filter. Refer to Care and Cleaning section.
	Temperature is set too high, then, set temperature to a lower setting.
	Air directional louvers positioned improperly. Position louvers for better air distribution.
	Front of units is blocked by drapes, blinds, furniture, etc. - restricts air distribution. Clear blockage in front of unit.
	Any open doors, windows, or registers may allow cold air to escape. Close any doors, windows, or registers.
	The room may be too warm. Allow additional time to remove "stored heat" from walls, ceiling, floor, and furniture.
<b>Air conditioner turns on and off rapidly</b>	Dirty or restricted air filter. Clean air filter.
	Outside temperature extremely hot. Set FAN speed to a higher setting to bring air past cooling coils more frequently.
	Check for potential obstructions blocking the outdoor intake/exhaust. Clear any obstructions.
<b>Noise when unit is cooling</b>	It is normal to hear the airflow. If too loud, set to a slower FAN setting.
	Window vibration - poor installation. Refer to installation instructions or check with installer.

Problem	Solution
<b>Water dripping INSIDE when unit is cooling.</b>	Improper installation. Tilt air conditioner slightly to the outside to allow water drainage. Refer to installation instructions - check with installer.
<b>Water dripping OUTSIDE when unit is cooling.</b>	Unit removing large quantity of moisture from humid room. This is normal during excessively humid days.
<b>Remote Sensing Deactivating Prematurely (some models)</b>	Remote control not located within range. Place remote control within 20 feet and pointed in the general direction of the air conditioner unit.
	Remote control signal obstructed. Remove obstruction.
<b>Room too cold</b>	Set temperature too low. Increase set temperature.
<b>Noise when unit starts</b>	A "da-da" sound may occur for thirty seconds when the unit is turned on due to the compressor starting. It is normal.









## LIMITED EXPRESS WARRANTY

**Congratulations on purchasing your new HVAC equipment. It's been designed for long life and reliable service, and is backed by one of the strongest warranties in the industry. Your unit automatically qualifies for the warranty coverage listed below, providing you keep your proof of purchase (receipt) for the equipment and meet the warranty conditions.**

### LIMITED ONE (1) YEAR EXPRESS WARRANTY

Comfort-Aire warrants this Room Air Conditioner to be free from defects in workmanship and materials for normal use and maintenance for one (1) year from the date of purchase by the original consumer. This Express Limited Warranty applies only when the Room Air Conditioner is installed and operated per Comfort-Aire installation and operating instructions for normal use.

### EXCEPTIONS

The Limited Express Warranty does not cover normal maintenance. Comfort-Aire recommends that regular inspection/maintenance be performed at least once a season. Additionally, labor charges, diagnostic charges, transportation charges for replacement of refrigerant or filters, and any other service calls/repairs are not covered by this Limited Warranty. It also does not cover any portion or component of the system that is not supplied by Comfort-Aire, regardless of the cause of failure of such portion or component.

### CONDITIONS FOR WARRANTY COVERAGE

Unit must be operated according to Comfort-Aire operating instructions included with the unit and cannot have been subjected to accident, alteration, improper repair, neglect or misuse, or an act of God (such as a flood)

- Serial numbers and/or rating plate have not been altered or removed
- Performance cannot be impaired by use of any product not authorized by Comfort-Aire, or by any adjustments or adaptations to components
- Damage has not been a result of inadequate wiring or voltage conditions, use during brown-out conditions, or circuit interruptions
- Air flow around any section of the unit has not been restricted
- Unit remains in the original installation

### DURATION OF WARRANTY & REGISTRATION

The warranty begins on the date of purchase by the original consumer. The consumer must retain a receipted bill of sale as proof of warranty period. Without this proof, the express warranty begins on the date of shipment from the factory.

### REMEDY PROVIDED BY THE LIMITED EXPRESS WARRANTY

The sole remedy under the Limited Warranty is replacement of the defective unit. Labor to diagnose and replace the defective unit is not covered by this Limited Express Warranty. If for any reason the replacement product is no longer available during the warranty period, Comfort-Aire shall have the right to allow a credit in the amount of the current suggested retail price of the product instead of providing replacement.

### LIMITATION OF LIABILITY

1. There are no other express or implied warranties. Comfort-Aire makes no warranty of merchantability. We do not warrant that the unit is suitable for any particular purpose or can be used in buildings or rooms of any particular size or condition except as specifically provided in this document. There are no other warranties, express or implied, which extend beyond the description in this document.
2. All warranties implied by law are limited in duration to the one-term of the warranty. **We will not be liable for any consequential or incidental damages caused by any defect in this unit.**
3. This warranty gives you specific legal rights and you may also have other rights which vary from state to state. Some states do not allow limitation on how long an implied warranty lasts or do not allow the exclusion or limitation of incidental or consequential damages, so the above limitations or exclusions may not apply to you.
4. No warranties are made for units sold outside the continental United States and Canada. Your distributor or final seller may provide a warranty on units sold outside these areas.
5. Comfort-Aire will not be liable for damages if our performance regarding warranty resolution is delayed by events beyond our control including accident, alteration, abuse, war, government restrictions, strikes, fire, flood, or other acts of God.

### HOW TO SUBMIT A WARRANTY CLAIM

If you have a warranty claim, notify you installer or dealer promptly.



Please visit  
[www.marsdelivers.com](http://www.marsdelivers.com)  
 to register your new product

KEEP THIS INFORMATION AS A RECORD OF YOUR PURCHASE	
PRODUCT IDENTIFICATION	INSTALLATION
_____ Model Number	_____ Installer Name (if used)
_____ Serial Number	_____ Phone Number/Contact Information
_____ Date of Purchase	_____ Date Installation Completed
Remember to retain your bill of sale as proof of warranty period.	

RXTS\_8-2021

The design and specifications are subject to change without prior notice for product improvement. Consult with the sales agency or manufacturer for details. Any updates to the manual will be uploaded to the service website, please check for the latest version.

---

Due to ongoing product improvements, specifications and dimensions are subject to change and correction without notice or incurring obligations. Determining the application and suitability for use of any product is the responsibility of the installer. Additionally, the installer is responsible for verifying dimensional data on the actual product prior to beginning any installation preparations.

Incentive and rebate programs have precise requirements as to product performance and certification. All products meet applicable regulations in effect on date of manufacture; however, certifications are not necessarily granted for the life of a product. Therefore, it is the responsibility of the applicant to determine whether a specific model qualifies for these incentive/rebate programs.

*Comfort-Aire*®

1900 Wellworth Ave., Jackson, MI 49203 • Ph. 517-787-2100 • [www.comfort-aire.com](http://www.comfort-aire.com)

